

Operation Manual



Wienold Glass and Material Lift

GML 500+/ 30

3' - 10.00"
(1.17 m)

DC [24V Winch]

Wienold-LIFTE.de

02/2020

Contents

Contents	Page
Basic procedures	3
General description	4
GML Series typ overview	5
COMPONENTS VIEW	
GML500+/30 K DC	
Electrical components	8
Safety instructions	9
Pre-operation inspection	14
Working area inspection	16
Function tests	17
Operating instructions	19
INSTALLATIONS	
GML500+/30 K DC	20
Lateral outrigger	21
Mast safety hook	22
Loading devices	23
Load preparation	24
Load centre	25
RAISING/LOWERING LOADS	
by electric winch (DC Series, 24V)	26
Loading/Transportation	27
Technical data	32
Declaration of conformity	33

Basic Procedures

Please read and comply with:



- The manufacturer's instructions and safety regulations.
- The operating and safety instructions for this lift.
- The inscriptions, labels and warning signs on this lift.
- The safety instructions and operating instructions at the job site.
- The current, local and legal safety regulations.

This lift fulfils the current CE regulations and norms, EN ISO 12100, as well as the machinery directive 2006/42/EG, when used and operated according to the manufacturer's recommendations.

It is the duty and responsibility of each operator to obey all regional rules and regulations concerning the safe usage of this lift.

Please read carefully and follow all of the safety instructions for this appliance before maintenance, repair or operation.

This is in compliance with all the manufacturer's recommendations and all of the legal guidelines as required by the government and local authorities.

In order to allow for a safe and appropriate use of this lift, it may only be used by persons who have been instructed by authorised specialists and who have been granted operative authorisation.

Repairs and maintenance of this lift are only to be undertaken by qualified and trained personnel without exception.

This lift is subject to an annual UVV-inspection by an authorised tester. Without a current UVV-test seal this lift must not be operated.

The owners and anyone hiring/borrowing this lift should have all construction parts undergo a complete inspection. All of the lift's functions must be thoroughly examined and inspected before sale or lease takes place. Damaged and malfunctioning parts must be repaired or replaced.

This operating manual is an essential requirement for all operators of this equipment. For this reason it must always remain in its appropriate place on the lift and always be readily available.

Norbert Wienold GmbH is constantly developing and improving this and other Wienold products. For this reason our appliances and products may be subject to modification without prior notice.

If you have any questions or queries, or if you notice any mistakes and/or deviations concerning the contents of this operating manual, please do not hesitate to contact us.

Contact: _____



Waldstr. 35a
D-48488 Emsbüren
Germany

Tel.: +49 5903 - 9394-0

Fax: +49 5903 - 9394-50

info@wienold-lifte.de

Wienold-LIFTE.de

General Description

GML500+/30 Wienold Glass and Material Lift

The GML500+/30 consists of a chassis and a mast element system. The lifting height is defined by the number of mast elements. The loading capacity is defined by both the model and the required lifting height.

There are various models with different lifting heights. All models extend the mast elements sequentially until the required working height is reached.

The various mast elements drive systems and their corresponding models are listed below:

per 24V Winch(DC Series)

On DC models, an automatic mast limit switch ensures an automatic deactivation of the lifting movement when the maximum lifting height has been reached and this switch also controls the cable tension when lowering.

The GML500+/30 is equipped with frontal outriggers which, depending on the model, may also be deployed as rear outriggers when used in combination with counterweights.

Different loading accessories are employed to raise, lower, hold and load up to the Safe Working Load (SWL). A lifting fork or a crane outrigger are generally available as loading accessories. These can be easily substituted.

Minor positioning of the lift during operation must always be done manually.

Transportation of persons with the lift is strictly prohibited!

Do not operate the lift in areas where an explosion hazard exists.

GML Series

GML500+ / 30 K DC with converter cart and 24V winch

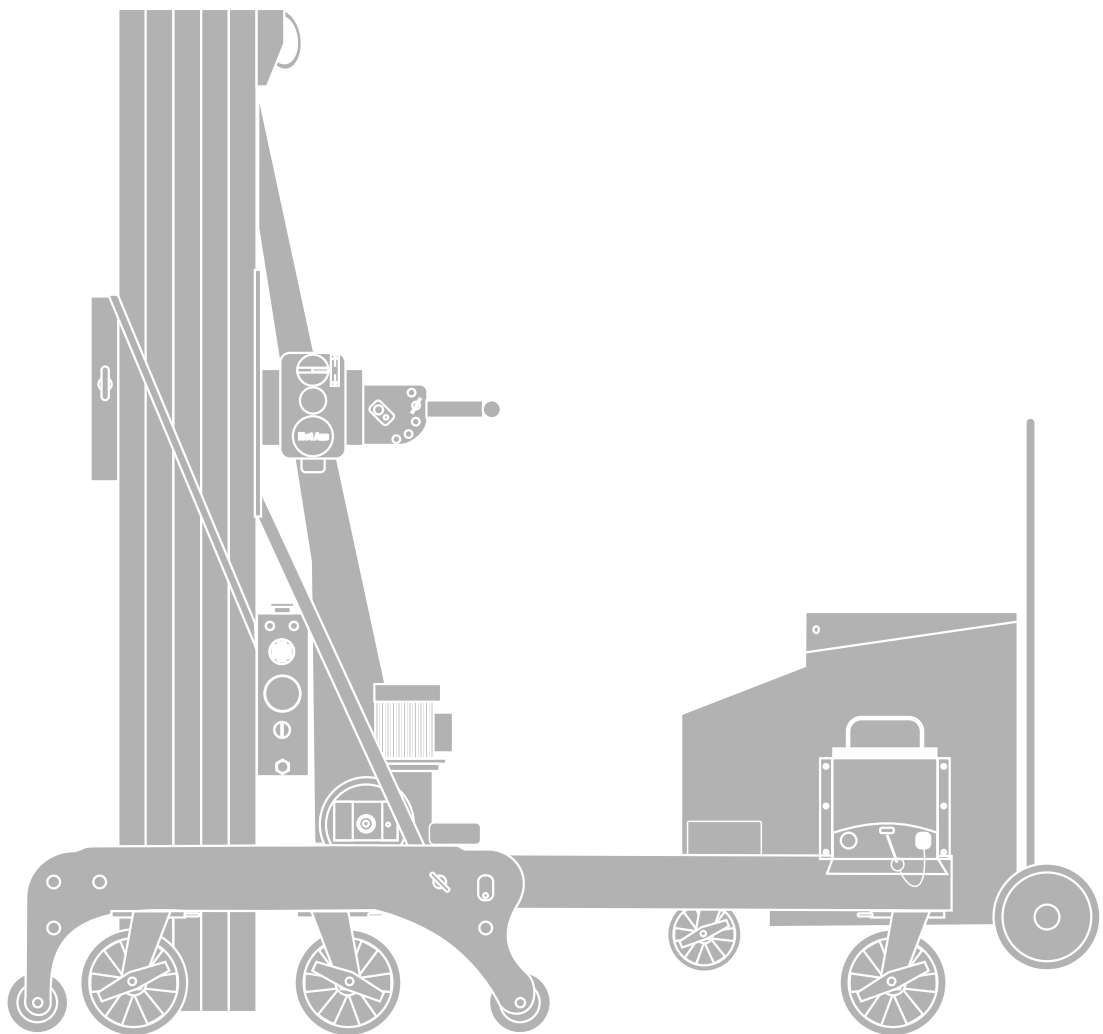

Components GML500+/30 K DC

With electrical 24V winch (DC).
Type GML500+/30 are equipped with lateral outriggers (standard).

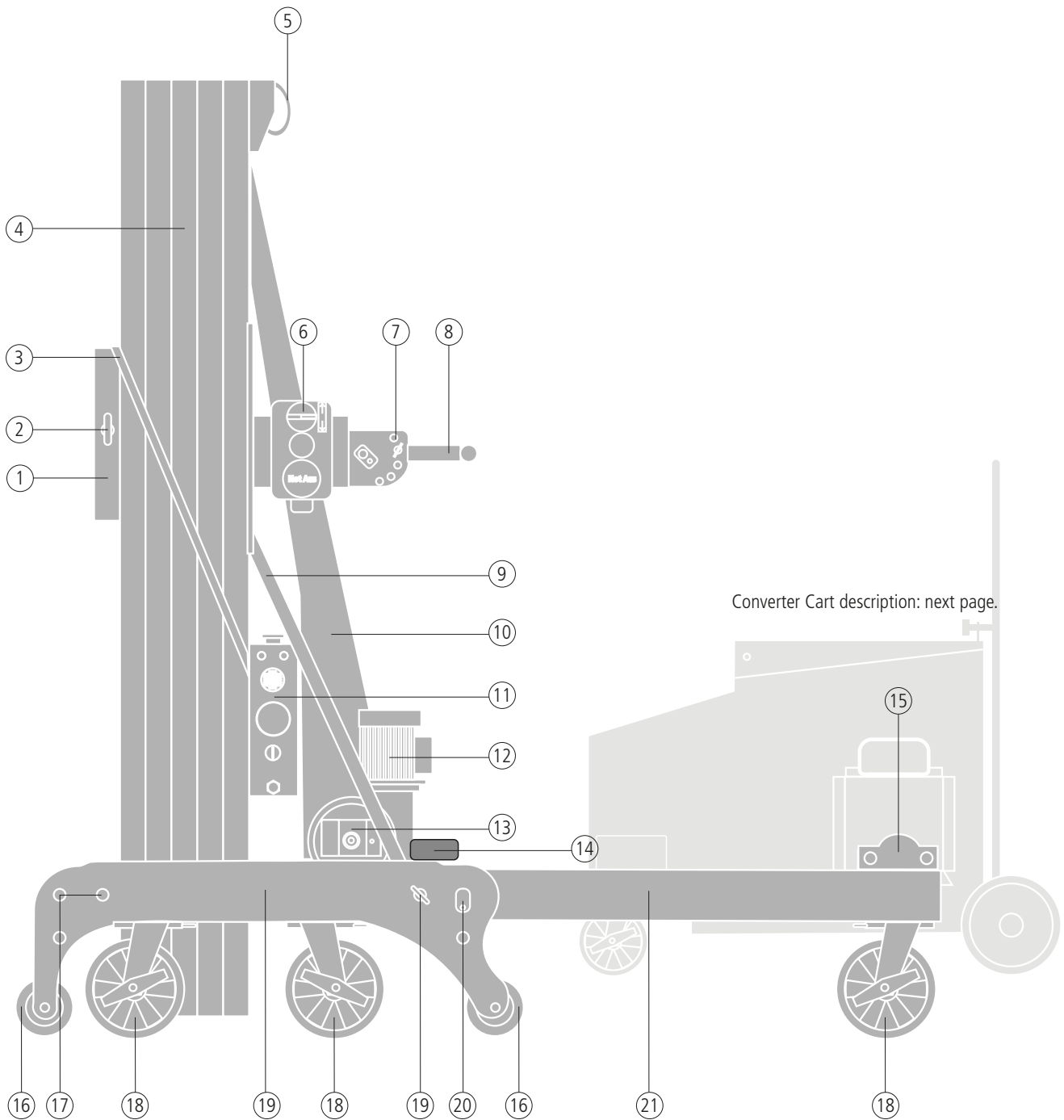

Converter Cart description: next page.

- | | | |
|--|------------------------------|------------------------------|
| 1) Carriage | 9) Stabilizer | 17) Holes for outrigger |
| 2) Bolt to secure attachments | 10) Cable cover | 18) Swivel caster with brake |
| 3) Hold down bar (for transportations) | 11) Electric control box | 19) Chassis |
| 4) Mast System | 12) Electric motor | 20) Securing pin |
| 5) Lifting eye | 13) Winch unit | 21) Outrigger |
| 6) Cable control | 14) Power supply | |
| 7) Push bar adjustment holes | 15) Slip-On for battery cart | |
| 8) Push bar | 16) Support wheel | |

Converter Cart GML/K DC

With electrical 24V winch (DC).

Left side:

Right side:

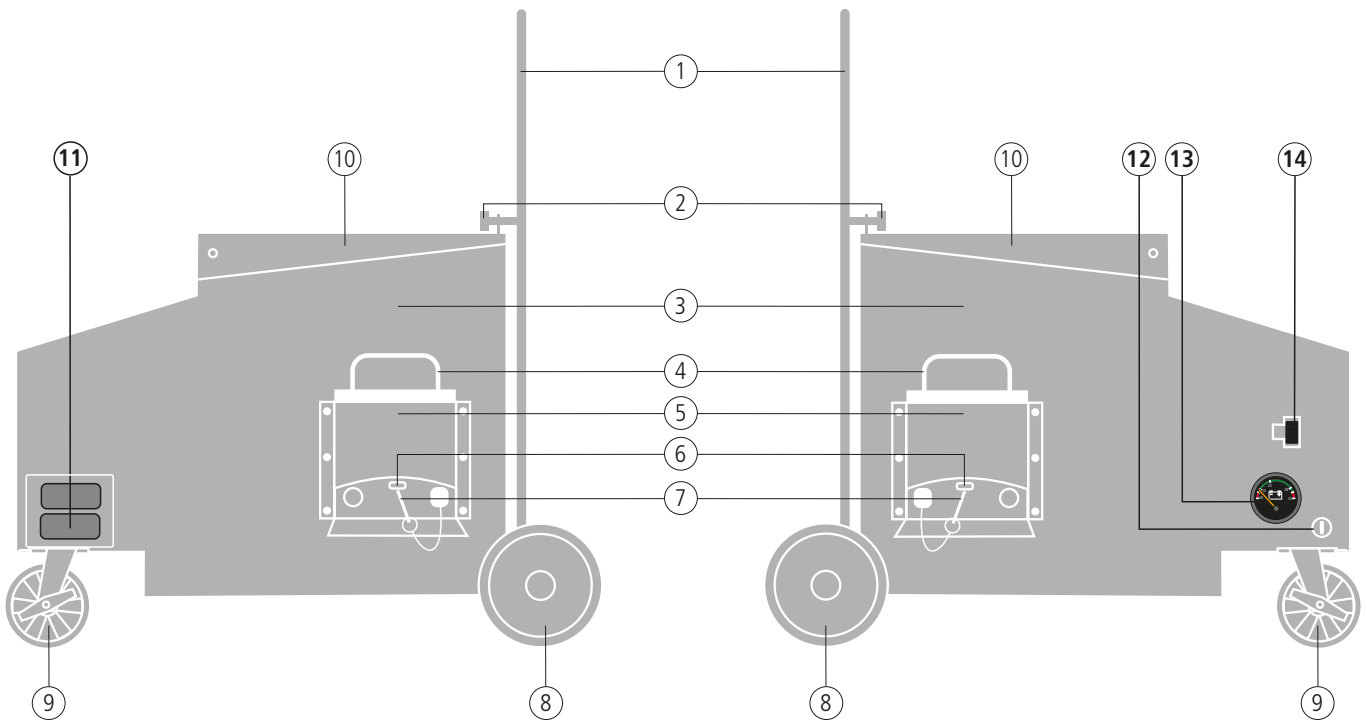

Left side:

11) Power supply

Both sides:

- 1) Push bar
- 2) Converter pack locking
- 3) Converter pack
- 4) Counterweights (3 pcs. each side)
- 5) Counterweight box (screwed)
- 6) Slip-On eye for Securing pin
- 7) Slip-On securing pin
- 8) Caster
- 9) Swivel caster with brake
- 10) Converter access

Right side:

- 12) Power switch
- 13) Voltmeter
- 14) 110 V / 230 V Power plug

Electric Components DC-Series

Control box and cable remote control.

Control box left side:

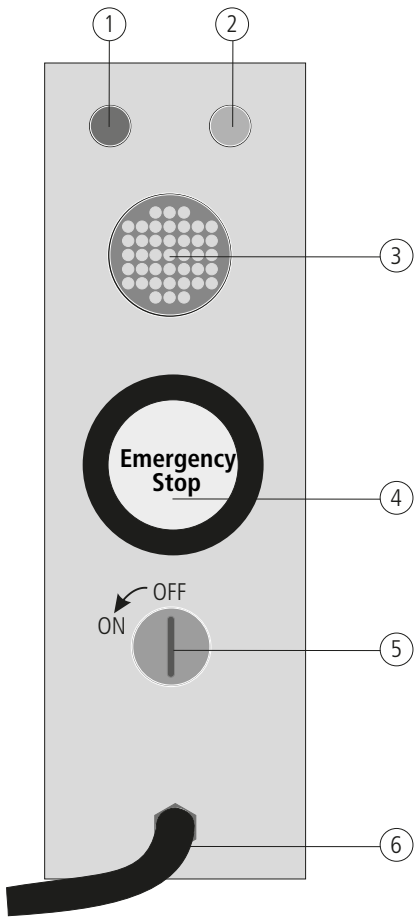

- 1) Green LED: ready to operate
- 2) Red LED: electrical interference
- 3) 24V socket for electrical attachments
- 4) Emergency Stop
- 5) Power switch (On/Off)
- 6) Cable control supply

Control box right side:

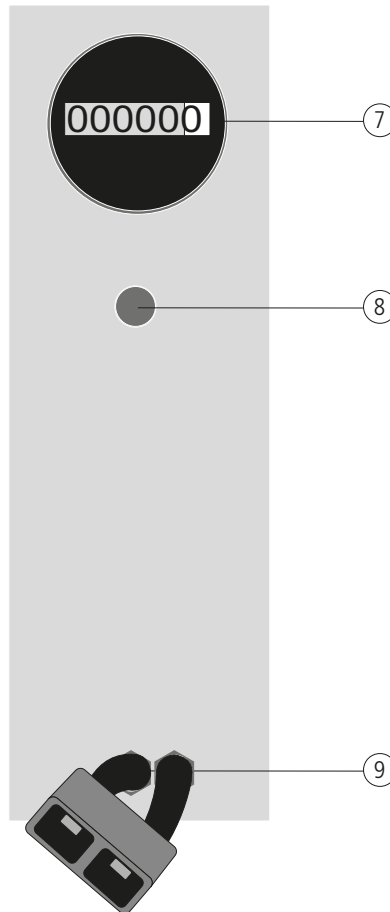

- 7) Hour meter
- 8) Fuse
- 9) Power supply

Control box bottom side:

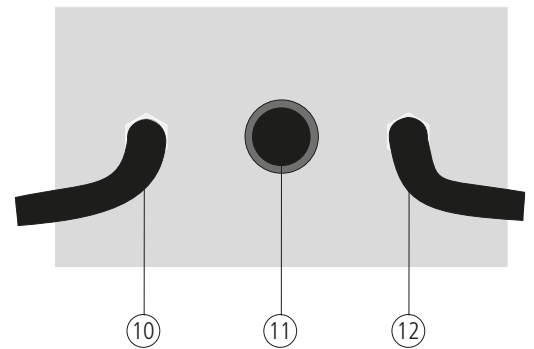

- 10) Limit switch supply
- 11) Emergency descent
- 12) Winch supply

Cable remote control:

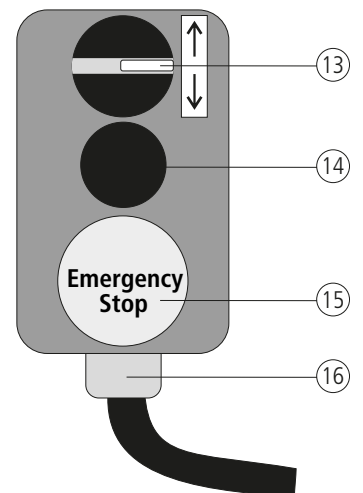

- 13) Switch UP/DOWN
- 14) Accessory control
- 15) Emergency Stop
- 16) Control box supply

Safety Instructions



Warning!

Failure to obey the instructions and safety regulations in this manual may result in death or serious injury.

Do Not Operate Unless:

- The personnel have been trained on this type of unit and are deemed competent. All operators should read the operating manual carefully.

1. Avoid hazardous situations.

Know and understand the safety regulations before going on to the next section.

2. Always perform a pre-operation inspection on the lift.
3. Inspect the working area thoroughly before using the lift.
4. Always perform the function test as per the operating manual prior to use.
5. Only use the lift as per the operating instructions. Any deviations are not acceptable. In case, you must always contact the owner of the equipment.

Read, understand and obey:



- a) the manufacturer's instructions and safety instructions.
- b) the operating manuals and safety instructions for the lift.
- c) the inscriptions, labels and warning signs on the lift.
- d) the safety instructions and work procedures on the job site.
- e) the relevant legislation in force for the equipment in use.

Safety Instructions

Wear Appropriate Personal Protective Equipment (PPE)

Always wear PPE before operating the lift including:

1. Safety helmets
2. Safety goggles
3. Safety shoes

Always check which PPE is required at each particular job site. Do not use the lift and do not execute any function tests without wearing the appropriate PPE.

Keep loose clothes, jewelry, hair etc. away from any moving parts and ensure appropriate PPE is worn whilst operating the unit. Keep hands and feet within the areas acceptable to operate the winch safely to raise or lower the unit.

Fall Hazards

Do not use this lift as a personnel lifting platform or step. Do not stand on the loading accessories (e.g. lifting fork etc.). Do not climb on the mast, the chassis or other components.

Tip-over hazards

Always ensure before either loading or lifting that the lift is positioned on a secure, solid, flat and horizontal subsurface.

Do not raise the load until all the available stabilisers and legs have been fully lowered and secured and the casters are in full contact with the work surface.

Do not raise the load until all outriggers are extended and the appropriate leg retainer pins are properly inserted into the chassis.



When using models with counterweights, only raise the load when the weight box has been completely filled with the specified counterweights.

A fixed and secured outrigger must not be re-adjusted as long as the lift is loaded or is in a raised position.

Prior to use, check the working area for steep slopes & drop-offs, holes and debris. Also check for instable, slippery or icy surfaces and other possible sources of danger.

Do not raise the load unless the loading accessories are correctly secured to the lift.

Do not use any blocks, stones, planks or any other items to balance the lift.

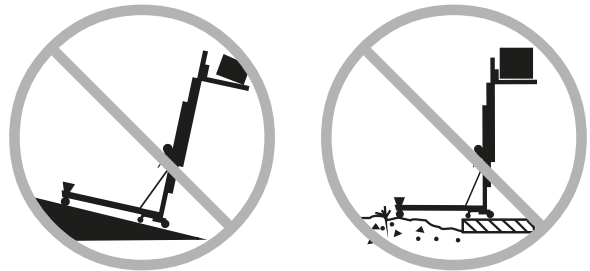

Do **not** move the lift with a raised load except for **very** minor positioning.

Never operate the lift if it is iced.

Never operate the lift in strong or gusty wind conditions. An increase in the load surface area will decrease lift stability when operating in windy conditions.

Never leave a load in a raised position when windy conditions may occur unless the lift is correctly tag lined.



Always ensure, when raising or lowering secured or overhanging loads, that no obstructions can interfere with the safe operation of the lift.

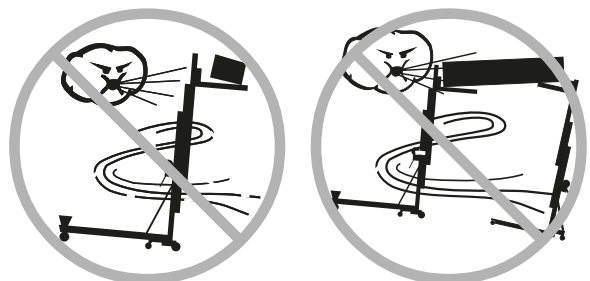

Safety Instructions

Electrocution Hazards - Danger to Life

This lift is not electrically insulated and will not provide protection from contact with or proximity to electrical current.

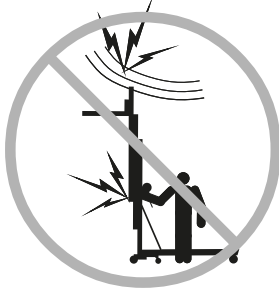

Keep away from the lift if it contacts electrical power cables. Personnel must not touch or operate the lift until the power conductors have been switched off.

Maintain safe distances away from electrical power conductors and appliances.

Please take into account the relevant current legal regulations and the following chart:

VOLTAGE	MINIMUM SAFETY DISTANCE
Phase-to-Phase	Meters
0 - 300 V	Avoid Contact
300 V - 50 kV	3,1 m
50 kV - 200 kV	4,6 m
200 kV - 350 kV	6,1 m
350 kV - 500 kV	7,6 m
500 kV - 7550 kV	10,7 m
750 kV - 1000 kV	13,7 m

Allow for mast movement and possible swaying and sagging of electrical cables. Be especially careful in strong or gusty wind conditions!

The unit is not to be used in conjunction with welding units fitted to the forks under any circumstances..

Injury Hazard

Do not hold on the winch cable and do not grasp into the winch itself.

Do not lean any ladders or scaffolding against the lift or the load.



Do not operate the lift on a movable/mobile surface or on a motor vehicle.

The Safe Working Load (SWL) must not be exceeded under any circumstances. Always refer to the load charts on the unit.

Avoid moving the lift with closed outriggers over debris or uneven ground.

Never replace lift parts that are important for stability or construction with parts with different weights and specifications. Only use original replacement parts. If the equipment is damaged or operating incorrectly you must contact the hirer immediately.

Only use the approved loading accessories with this lift.

Lifting Hazards

Always use the correct lifting techniques when loading or tilting the lift. Personnel should be trained and competent to use the unit correctly.

Always use the correct lifting techniques when installing and de-installing the loading accessories.

Operating the Lift

Ensure that the safety brakes are engaged prior to operating the lift in order to avoid rolling.

Do not ever stand or allow others to stand under the loading accessories.

Always remain behind the winch when raising or lowering. Do not stand on the chassis, the outriggers or any other components.

Safety Instructions

Crushing Hazards

Do not raise if the load is not

1. correctly centred on the loading accessory.
2. correctly secured to the loading accessory.

Never stand under the load as it is being raised or lowered or suspended. Do not allow others to stand in the lifting area when the unit is being operated.



Standing under the load is prohibited. The load may fall from between 30 and 91 cm before the safety brake mechanism activates the locking of the mast elements.

Do not lower the load unless the area below is clear of personnel and obstructions.

Keep hands and fingers away from the winch, the folding outriggers, loading accessories and any other potential pinch points.

Maintain a firm grasp on the loading accessory when the safety bolt is removed. Otherwise the loading accessory will fall.

Maintain a firm grasp on the outrigger when the safety bolt is removed. Otherwise the outrigger will fall.

Maintain a firm grasp on the winch crank handle. The winch brakes engage automatically when you stop winding. The crank handle must not move when you stop winding.

Standard Forks

Only use appropriate loading accessories when lifting a load. Always ensure before loading that the loading accessory used is suitable for the load and is correctly secured.

Only raise the load when the loading accessory has been correctly installed and the load has been correctly aligned and secured. Always take into account the relation between lifting height and load center .

Collision Hazards

Check the working area for overhead obstructions or other potential sources of danger.

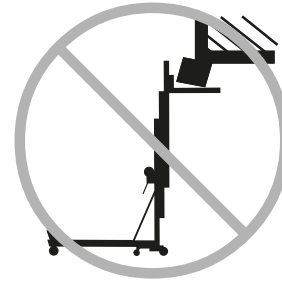

Always plan your route if transporting a load on site using the unit. Avoid sharp turns, inclines or voids in the ground. Only move the lift when in transport position!

Loading

When loading the lift (for transport), always ensure that the lift and the transport vehicle are on an even subsurface.

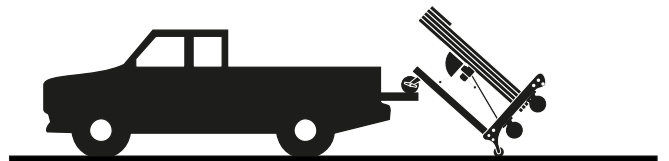

Always use the correct lifting techniques and always use the snap hook on top of the lift when using a crane or the forklift receptors when loading with a forklift.

Safety Instructions

Damaged Lift Hazards

Do not operate a damaged or malfunctioning lift.



Do not use a lift with a worn, frayed, kinked or damaged cable.

Always conduct a thorough pre-operation inspection prior to each use.

Any damage, faults or failure of the unit must be assessed by a competent person trained to identify such matters and instructed for repair work on this lift. Non-appliance to this rule may lead to serious injury and possible danger to life.

Always ensure that all warning signs are legible and in place.

Always ensure that the operating manual is complete, legible and placed in the storage container installed on the lift.

Maintain proper lubrication on the winch. Do not allow oil or grease on the brake surfaces or on the mast elements.

Only use silicon spray when lubricating the mast elements (no oil or grease). Avoid spraying onto the brake surfaces.

Hazard due to improper use

Never leave a loaded lift unattended or suspended. Unauthorised personnel may attempt to operate the lift without having been correctly briefed and thereby create an unsafe situation.

Legend - Warning Signs

Wienold lifts, appliances & machines use symbols, colour codes and signal words to identify the following:



Safety Alert Symbol:

This is used to alert personnel to potential injury hazards. Obey all safety messages that follow this symbol to avoid possible injury or death.



RED = DANGER

This is used to indicate the presence of an imminently hazardous situation which, if not avoided, will result in death or serious injury.



ORANGE = WARNING

This is used to indicate the presence of a potentially hazardous situation which, if not avoided, could result in death or serious injury.



YELLOW = CAUTION

This is used to indicate the presence of a potentially hazardous situation which, if not avoided, may cause property damage or could result in death or serious injury..

Pre-operation Inspection



Non compliance with the instructions and safety rules in this operating manual may result in serious injury or accidents including death!

Do not operate the lift unless :

The personnel have been trained on this type of unit and are deemed competent. All operators should read the operating manual carefully.

1. Avoid hazardous situations.

Know and understand the safety regulations before going on to the next section.

2. Always perform a pre-operation inspection on the lift.

3. Inspect the working area thoroughly before using the lift.

4. Always perform the function test as per the operating manual prior to use.

5. Only use the lift as per the operating instructions. Any deviations are not acceptable. In case, you must always contact the owner of the equipment.

Fundamentals

The pre-operation inspection is a visual inspection which must always be performed by the operator prior to each work assignment.

This inspection is designed to identify and avoid possible malfunctions of the lift before the operator tests it.

Check the lift for modifications, damages and loose or missing parts.

A malfunctioning or modified lift must not be operated under any circumstances.

If any damage or unauthorised deviation from factory delivered condition is discovered, the lift must be removed from service and appropriately tagged. Additionally, the owner of the equipment must be informed.

Repairs to the lift may only be undertaken by a qualified service technician in compliance with the manufacturer's specifications.

The operator must perform a new pre-operation inspection after any repairs are completed, before going on to the function tests.



Read, understand and obey:

- a) the manufacturer's instructions and safety instructions.
- b) the operating manuals and safety instructions for the lift.
- c) the inscriptions, labels and warning signs on the lift.
- d) the safety instructions and work procedures on the job site.
- e) the relevant legislation in force for the equipment in use.

Pre-operation Inspection

Please ensure

that the operating manual is complete, legible and placed in the storage container installed on the lift.

Please ensure

that all warning signs and labels are both legible and correctly positioned. For further information see **Warning Signs** section.

Check

the following components and areas for damage, modifications, and incorrectly installed or missing parts.

- Chassis and base components
- Outriggers, support legs and stabilisers
- Wheels and tyres
- Mast elements and components
- Casters and swivel casters
- Winch, cable, cable anchor, pulleys
- Loading carriage including safety bolts and loading accessories
- Mast element transport safety hook
- Bolts, pins, screws and nuts
- Other fastening and safety devices

Check the entire lift and loading devices for:

- Bents or damage
- Corrosion or rust
- Cracks in welds or structural components
- Defects on the winch/cable

Please ensure

1. that all structural and other corresponding components such as fasteners, pins, bolts and locks are correctly installed and undamaged. Also ensure that the brakes on the lift are engaged and that the lift is in a safe position.
2. that the lift has a minimum of 4 layers of cable on the winch drum when the loading accessory is fully lowered.

DC Machines

In addition to the checks of lifts with a manual winch, when using electrical or converter operated lifts the following inspections must be undertaken:

Function tests for :

- Automatic mast limit switch
- All control elements
- All switches
- Electric winch
- Cables/cable connections and power outlets
- Converter cart (DC-series only)

Working Area Inspection



Non compliance with the instructions and safety regulations in this operating manual may result in death or serious injury!

Do Not Operate Unless:

The personnel have been trained on this type of unit and are deemed competent. All operators should read the operating manual carefully.

1. Avoid hazardous situations.

Know and understand the safety regulations before going on to the next section.

2. Always perform a pre-operation inspection on the lift.

3. Inspect the working area thoroughly before using the lift.

4. Always perform the function test as per the operating manual prior to use.

5. Only use the lift as per the operating instructions. Any deviations are not acceptable. In case, you must always contact the owner of the equipment.

Fundamentals

The working area inspection helps the operator to determine if the working area is suitable for safe lift operation. The inspection should be performed by the operator prior to moving the lift to the working area.

It is the operator's responsibility to read and know the section on working area hazards and to avoid them while moving, setting up or operating the lift.

Ensure the unit is working on solid ground and the loadings applied by the unit will not cause damage or create additional floor loading.

Avoid sources of danger!

Do not operate the lift if you cannot guarantee a safe operation due to one or more of the following sources of danger:

- Inclines, holes or swells on the work surface or debris
- Unstable subsurfaces at the working area
- Insufficient subsurface foundation at the working area
- Subsurfaces with holes, obstructions etc.
- Overhead obstructions such as:
- Beams, electric cables and ropes/wires
- High voltage cables
- Unsuitable wind and weather conditions
- All other possible unsafe surfaces and conditions



Read, understand and obey:

- a) the manufacturer's instructions and safety instructions.
- b) the operating manuals and safety instructions for the lift.
- c) the inscriptions, labels and warning signs on the lift.
- d) the safety instructions and work procedures on the job site.
- e) the relevant legislation in force for the equipment in use.

Function Tests



Non compliance with the instructions and safety regulations in this operating manual may result in death or serious injury!

Do Not Operate Unless:

The personnel have been trained on this type of unit and are deemed competent. All operators should read the operating manual carefully.

1. Avoid hazardous situations.

Know and understand the safety regulations before going on to the next section.

2. Always perform a pre-operation inspection on the lift.

3. Inspect the working area thoroughly before using the lift.

4. Always perform the function test as per the operating manual prior to use.

5. Only use the lift as per the operating instructions. Any deviations are not acceptable. In case, you must always contact the owner of the equipment.

Fundamentals

The function tests are designed to identify malfunctions before the lift goes into service.

The operator must follow the step-by-step instructions and test all lift functions.

A malfunctioning lift must not be operated under any circumstances.

If any malfunctions are discovered the lift must be removed from service and appropriately tagged. Further use of the lift is prohibited.

Repairs to the lift may only be undertaken by a qualified service technician in compliance with the manufacturer's specifications.

When repair work has been successfully completed the operator must perform another pre-operation inspection and repeat the function tests. Only then may the lift be operated.



Read, understand and obey:

- a) the manufacturer's instructions and safety instructions.
- b) the operating manuals and safety instructions for the lift.
- c) the inscriptions, labels and warning signs on the lift.
- d) the safety instructions and work procedures on the job site.
- e) the relevant legislation in force for the equipment in use.

Function Tests DC Models

Electric Cable Winches

Electric Winches

RAISING:

- Disengage the mast element transport safety hook and raise the loading carriage to half of the maximum height of the mast system by using the remote control unit.
- Install a loading accessory (e.g. lifting fork).
(See chapter: Installation)
- Raise the mast by turning the rotary switch on the remote control unit to **RAISING** (arrow up). The winch drive will remain activated as long as the switch is held in place.

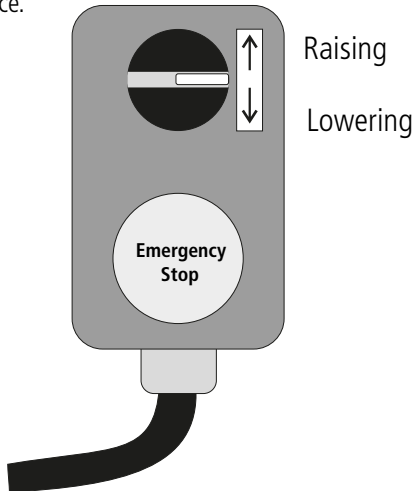

- >> The winch should turn evenly without lagging or jamming.
- >> An even and adjacent unwinding of the cable on the winch drum should occur. (see figure 1)

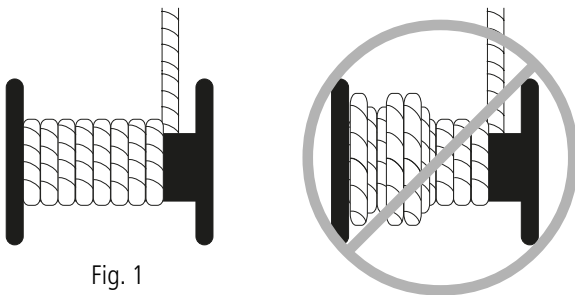

Fig. 1

Winch Deactivation

The winch stops automatically when the rotary switch is released (Raising/Lowering).

- >> The winch must stop and remain still.
- >> The mast must not sink independently.
- >> Cable tension must remain constant.

Mast System and Consecutive Extension

Different models have different extension heights. The extension height depends on the number of mast elements. A model with more mast elements will achieve a greater lifting height (see section Technical Data).

RAISING:

- Disengage the mast element transport safety hook and turn the rotary switch on the remote control unit in the direction **LOWERING** (arrow down) or **RAISING** (arrow up) as required to move the loading carriage to the height of the winch.
- Install a loading accessory (e.g. lifting fork).
(See chapter: Installation)
- Raise the mast by turning the rotary switch on the remote control unit to **RAISING** (arrow up). The winch drive will remain activated as long as the switch is held in place.

>> **When the loading carriage is fully extended, the first mast element should follow easily and without blockage.**

When the first mast element is fully extended, the second mast element should follow easily and without blockage.

Further raising should ensure that successive mast elements reach their full extension easily and without blockage.

LOWERING:

- Lower the mast by turning the rotary switch on the remote control unit to **LOWERING** (arrow down). The winch drive will remain activated as long as the switch is held in place.

>> **The successive mast elements must retract completely without snagging or blocking and in the reverse order when lowering.**

>> **Cable tension must remain constant.**

Operating Instructions



Do Not Operate Unless:

The personnel have been trained on this type of unit and are deemed competent. All operators should read the operating manual carefully.

1. Avoid hazardous situations.

Know and understand the safety regulations before going on to the next section.

2. Always perform a pre-operation inspection on the lift.

3. Inspect the working area thoroughly before using the lift.

4. Always perform the function test as per the operating manual prior to use.

5. Only use the lift as per the operating instructions. Any deviations are not acceptable. In case, you must always contact the owner of the equipment.

Fundamentals

Using the lift for anything other than lifting loads is unsafe.

If more than one operator is expected to use a lift at different times during the same work shift, each individual operator is expected to know and follow all of the safety regulations and instructions in the operating manual.

This means that every new lift operator should know and adhere to the safety regulations and instructions described in the previous chapters before operating the lift.

Therefore, the following tasks must be undertaken by each operator before initial operation:

- Read and understand this operating manual
- Pre-operation inspection
- Function tests
- Working area inspection
- Operating instructions
- Compliance with and application of the information in the load capacity chart

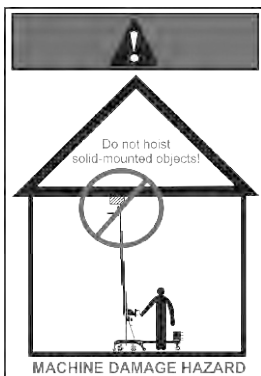

MACHINE DAMAGE HAZARD

Do not hoist solid-mounted objects!

Do not wedge the lift with immovable objects, which could result in tipping-over.

! WARNING:
Never move the lift with a raised load!
Only allow for minor position changes.
Avoid sudden movements.

! CAUTION:
 The loading capacity varies subject to model, design and installed loading accessory.
Never exceed the values listed in the loading capacity chart and the load centre chart when raising a load.

Installation GML/K DC

Outrigger and Converter Cart .

Set up the lift on firm and level ground only.

Ensure that all caster safety brakes on the chassis are engaged during set up.

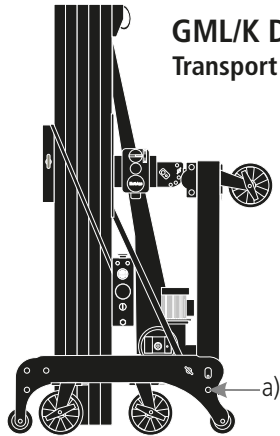

GML/K DC
Transport position:

1. Maintain a firm grip on the outrigger before you proceed with step 2! The outrigger may fall unexpectedly. Always lower the outriggers individually and one side after the other.
2. Remove the socket pin (a) completely from the chassis.

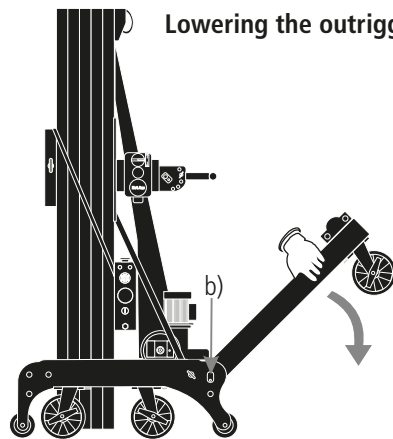

Lowering the outrigger:

3. Lower the outrigger carefully until the wheels are in full contact with the floor surface.

Please note:
The front fixing pin on the chassis (b) works as an axle when lowering the outrigger. The outrigger cannot be removed.

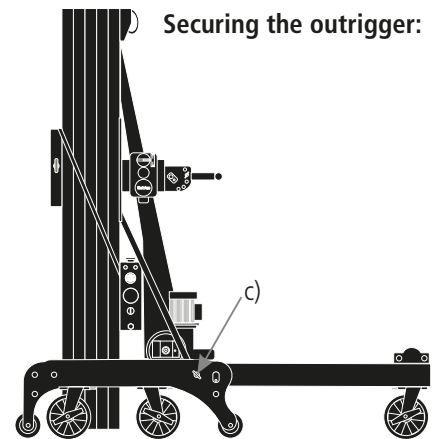

Securing the outrigger:

4. Place the socket pin in the upper rear slot (c) in order to re-connect outrigger and chassis.
5. Repeat steps 1 to 4 for the outrigger on the opposite side.

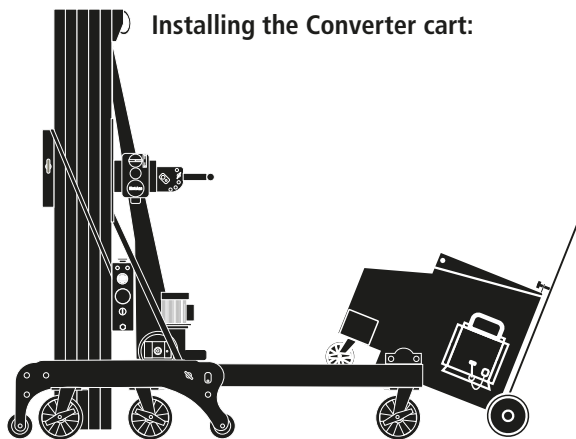

Installing the Converter cart:

6. Tilt the Converter cart slightly and push it on the back end onto the outrigger - until it is locked on both sides into the slip-on.

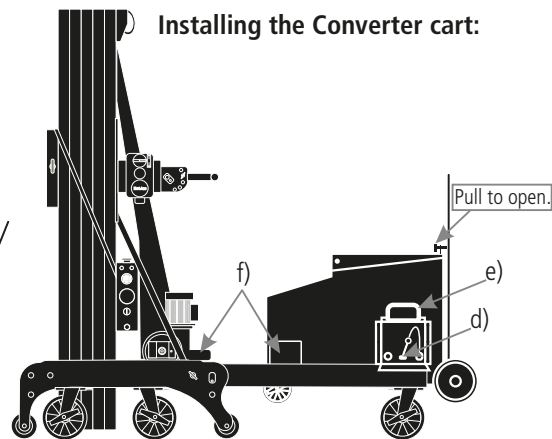

Installing the Converter cart:

7. To fix the Converter cart, insert the locking bolt through the slip-on eye (d) on both sides of the Converter cart.
8. In case if not fulfilled: fill up 3 counterweights (e) in the boxes on the left and right side of the Converter Cart.
- 9) Connect power supplies between winch and converter cart (f).



WARNING:

1. NEVER operate the GML/DC unless the Converter cart is completely filled!
2. Never operate the lift with only one outrigger!
3. Both outriggers must be pointing in the same direction! Otherwise the lift must not be operated!
4. Never move the lift with a raised load! Only allow for minor position changes.
5. Avoid sudden movements.

Installation Lateral outrigger

Lateral outriggers are standard

Set up the lift on firm and level ground only.

Ensure that all caster safety brakes on the chassis are engaged during set up.

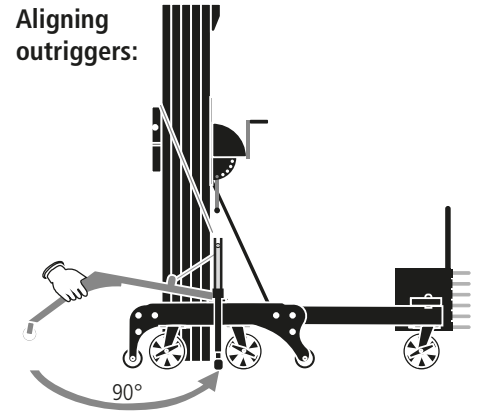
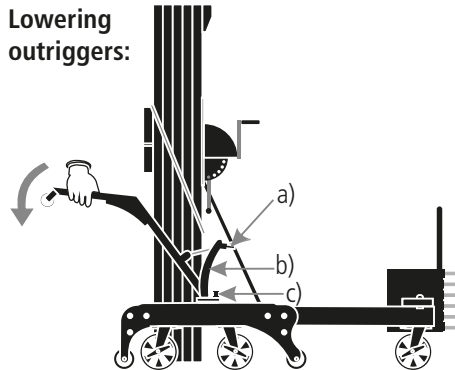
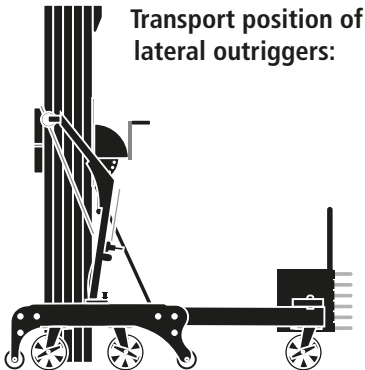

The models GML 500+ /30 lifting heights of more than 5 metres. In order to increase the stability of the lift, the lateral outriggers must always be installed.

1. Hold the outrigger firmly. Press down the brake plate (a) on the support strut (b). Lower the outrigger towards the front until the caster is approximately 5 - 10 cm from the work surface.

2. Pull the locking pin (c) on the adjustment plate upwards and maintain a solid grip on it in order to rotate the outrigger to the desired position.

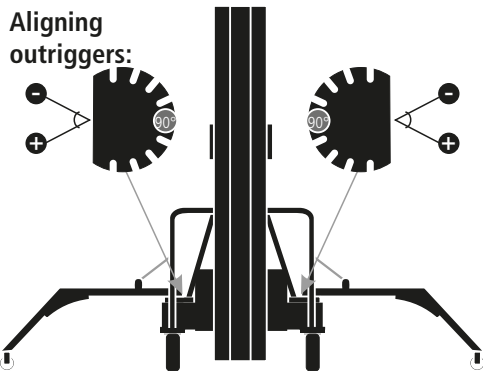

Setting Example

90° lateral outrigger alignment.

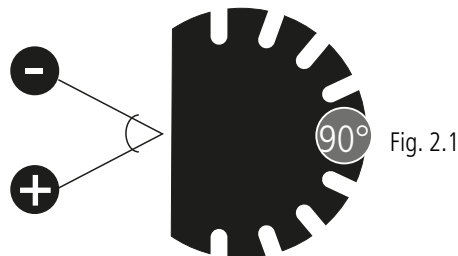

3. To secure the outrigger, release the locking pin (Fig. 2.1). Ensure that the locking pin slips correctly into the adjustment notch (Fig. 2.2). Shake the outrigger lightly to verify that the locking pin is correctly locked in place.

4. Repeat steps 1 - 3 for the second outrigger.

1. Never operate model GML 500+ /30 (Lifting height > 5,00m) without lateral outriggers!
2. Both lateral outriggers must have the same alignment on each side.
3. The locking pins must be correctly locked in the notch on the adjustment plate.
4. Never move the lift with a raised load! Only allow for minor position changes.
5. Avoid sudden movements.

Disengaging/Re-engaging the Mast Safety Hook

Removing/fitting the safety bar

Always ensure that the lift is in the correct operating position and that the safety brakes on the wheels and swivel casters are engaged before attempting to dismantle or refit the mast element transport safety hook.

Lowering the carriage:

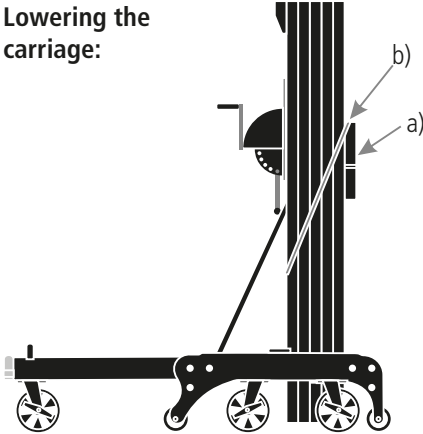

1. Lower the carriage (a) slightly to loosen the safety bar (b) on the carriage. This is done by winding the crank handle on the winch a little to the right.

Removing the mast element transport safety hook:

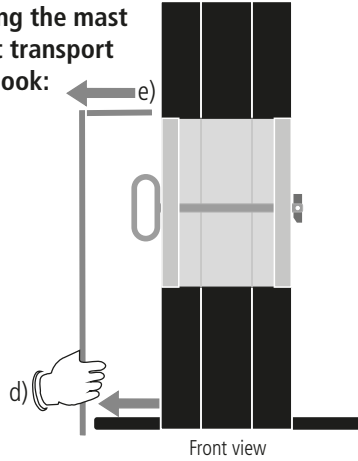

2. Grip the safety bar at the BOTTOM (d) and pull it towards you until it is able to pass by the mast system (e).

Repositioning the mast element transport safety hook:



3. Maintain a firm grip on the bottom of the safety bar and move the TOP of the safety bar to the first mast section (in the direction of the winch).

4. Release the grip on the BOTTOM of the safety bar and slide the TOP of the safety bar slowly into the first mast section.

Fitting the mast element transport safety hook

In order to reset the mast element transport safety hook, repeat the above steps in reverse order:

1. Grip on the bottom and pull.
2. Slip the hook past the mast system.
3. Refit the safety bar at the front, above the carriage.
4. Wind the winch slightly to the left. (Raise the carriage)



WARNING:

The greater the distance between the load and the carriage, the lower the allowed loading capacity! See load centre chart.

Standard Loading Device Installation

Fitting/removing a lifting fork or crane outrigger to/from the carriage

Set up the lift on firm and level ground only.

Ensure that all caster safety brakes on the chassis are engaged during set up.

Aligning the carriage:

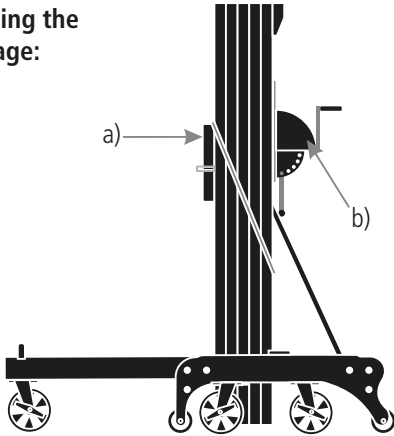

1. In order to install the lifting fork easily to the carriage, bring the carriage (a) to a suitable height by winding the winch (b).

Unlocking the safety bolt:

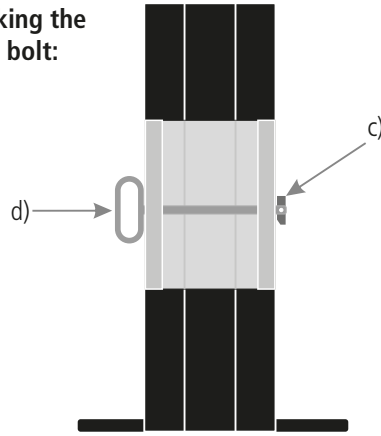

2. Release the splint (c) to enable removal of the safety bolt (d).

Securing and releasing the safety bolt:

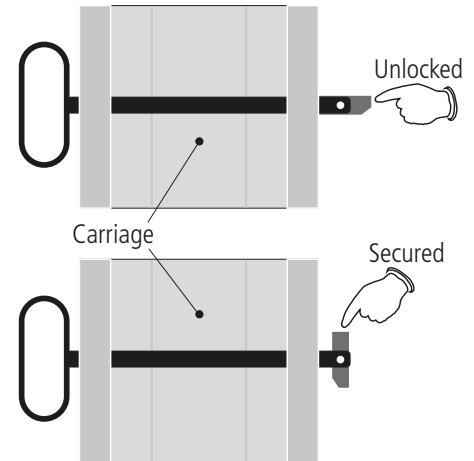

Installing the lifting fork from UNDERNEATH: (Low loading height)

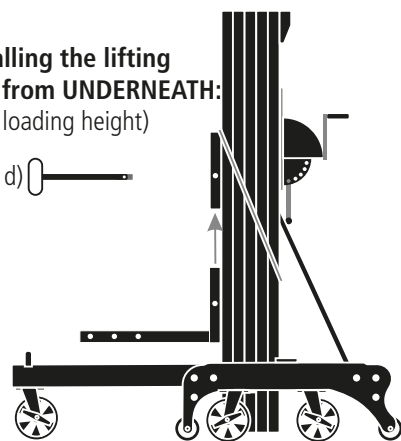

3. Remove the disengaged safety bolt (d) completely from the carriage.
4. Install the lifting fork on the carriage from **underneath**. **Align the slots on the lifting fork with those on the carriage.**
5. When both slots are at the same height, insert the safety bolt through the carriage and the loading accessory.
6. To secure the bolt, vertically install the splint (= "secured" position).

Installing the lifting fork from ABOVE: (More lifting height)

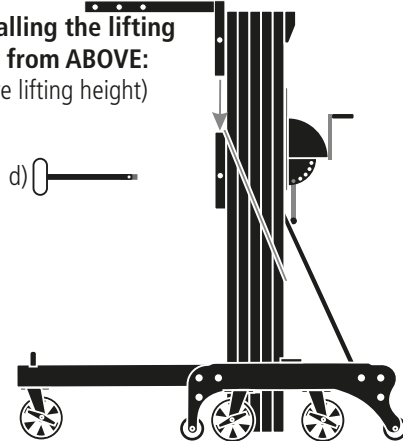

3. Remove the disengaged safety bolt (d) completely from the carriage.
4. Install the lifting fork on the carriage from **above**. **Align the slots on the lifting fork with those on the carriage.**
5. When both slots are at the same height, insert the safety bolt through the carriage and the loading accessory.
6. To secure the bolt, vertically install the splint (= "secured" position).

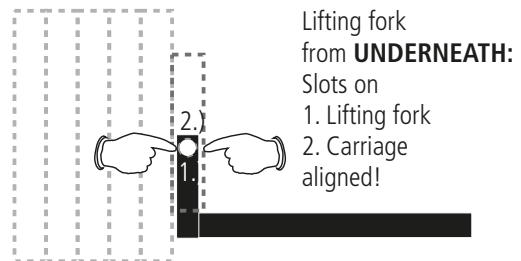

Lifting fork from **UNDERNEATH**:
Slots on
1. Lifting fork
2. Carriage aligned!

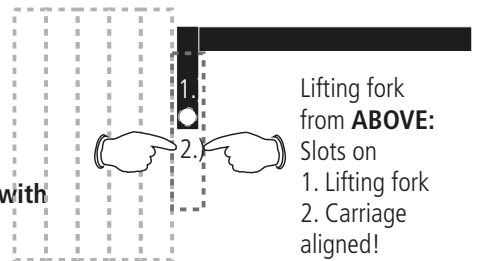

Lifting fork from **ABOVE**:
Slots on
1. Lifting fork
2. Carriage aligned!

! WARNING:

Ensure that the forks of the lift are not bent or damaged prior to use!

Load Positioning

Positioning and securing the load.

**Ensure that the loads are centered and secured to the loading accessory before lifting.
The safety brakes must be engaged before lifting.**

Position the load correctly on the loading accessory being used. Ensure that the load is adequately secured! Incorrectly positioned and/or incorrectly secured loads may lead to accidents that result in death or serious injury!

Load Positioning Instructions

1. Determine the weight of the load and identify the location of its load centre.
2. Position the load
 - a) with its load centre as close as possible to the mast system/carriage
 - b) in the centre of the loading accessory
3. Measure the distance between the mast system/carriage and the load centre of the load that is positioned on the loading accessory.
4. Always refer to the load centre chart to ensure that the lift is capable of lifting the load in its current position.
5. Ensure that the load is adequately secured.
6. Always align the large swivel casters on the chassis so that the maximum distance possible between them is achieved when working with the maximum allowed load.

Load Centre Instructions

A load centre is defined as the balancing point (centre of gravity) of a load. The load centre must always be positioned within the load centre zone as prescribed in the load centre chart!

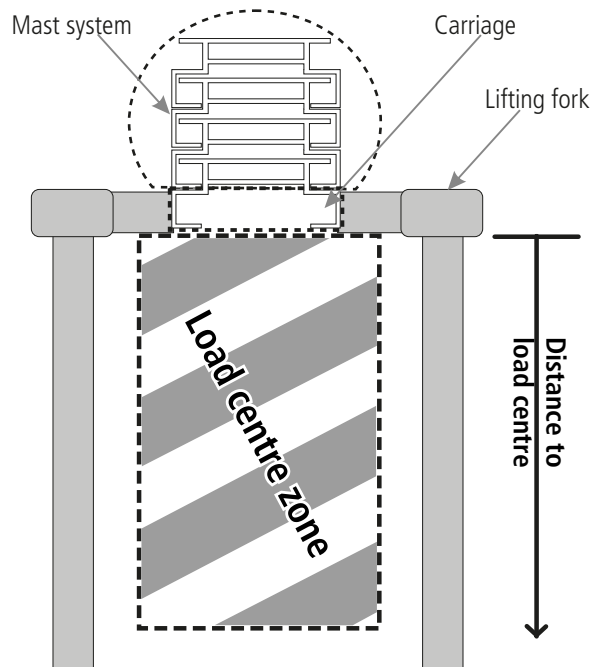

On both sides of the chassis

1. The front caster has to face FORWARD.
2. The rear caster has to face BACKWARDS.



Ensure that the load being lifted does not exceed the maximum load carrying capacity relative to the current load centre.

Always obey the specifications on the load carrying capacity chart. Do not ever exceed the prescribed specifications - under any circumstances!

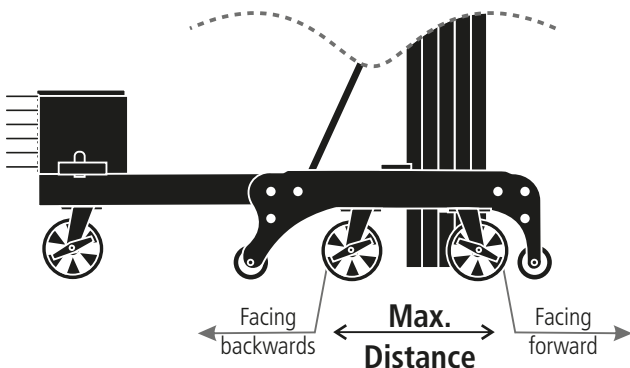

WARNING:

Positioning the load centre of a load outside of the load centre zone may lead to accidents that result in death or serious injury!

Load Centre

Positioning a load in relation to the load centre.

Ensure that the loads are centered and secured at the loading accessory before lifting.
The safety brakes must be engaged before lifting.

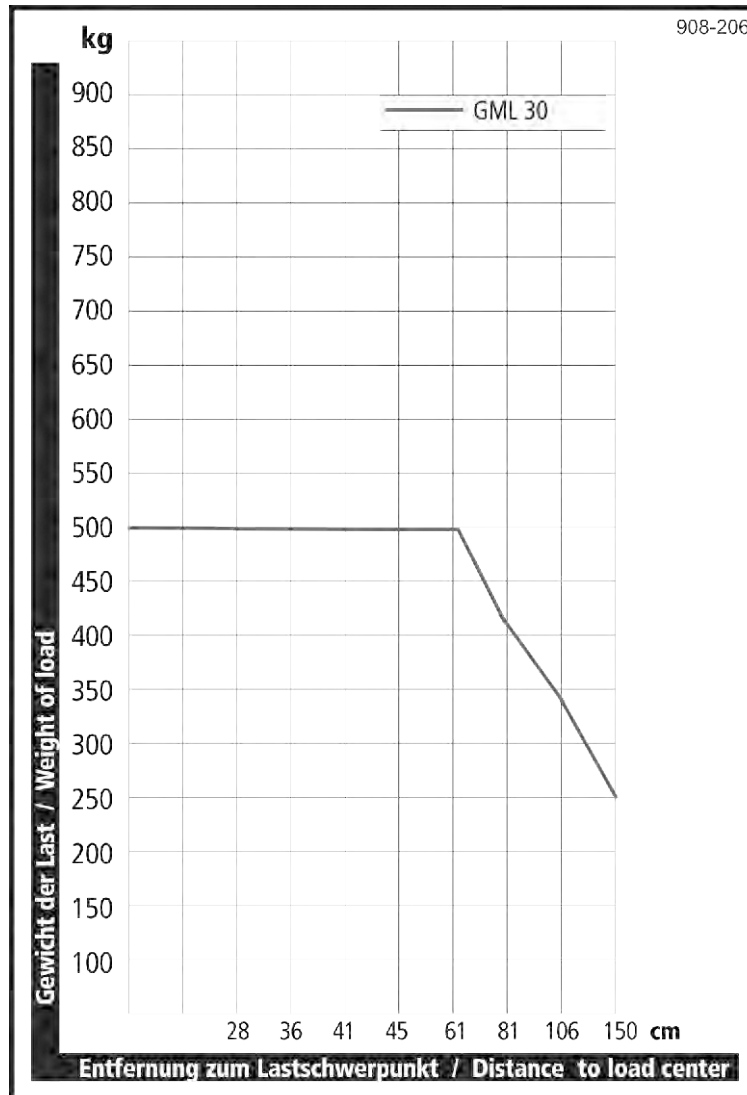
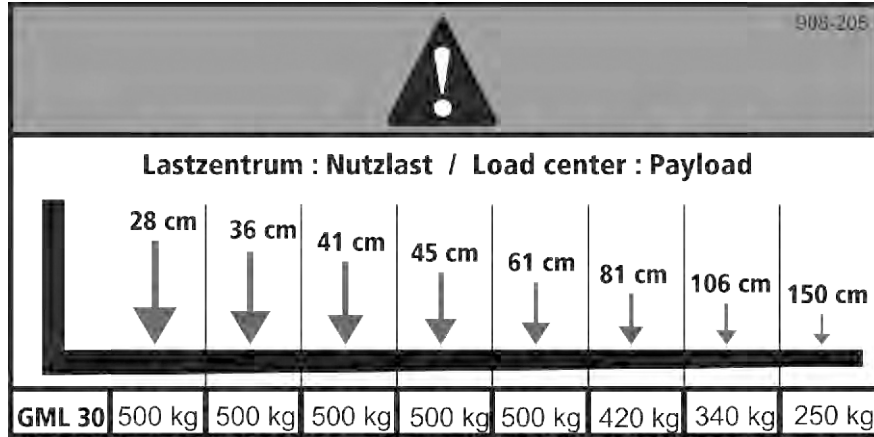

WARNING

Positioning the load centre of a load outside of the load centre zone may lead to accidents that result in death or serious injury!

Wienold Glass and Material Lift GML 500+

Raising and Lowering with an DC-Electric Winch.

Operating the electric winch on DC-Models (24V).

Operate the lift on firm and level ground only. Perform a PRE-OPERATION function test and convert the lift to the operating position as described in the section headed "Installation".

Ensure that all safety brakes on the swivel casters are engaged when working with a load.

24V PowerPack Electric Winch

1. Centre the load on the loading accessory and secure it against toppling.

2. Ensure that the battery wagon is converted to its operating position as described in the section heading **INSTALLATION GML /K DC**.

3. Connect the plug and the coupling of the converter cart and winch in order to supply the winch with energy.

4. The status of the Converter by looking at the voltmeter display (is always : 23V).

5. To **switch on** the winch insert the key into the key switch 8) and turn it TO THE LEFT. When the green signal lamp 4) is on, the winch is ready to be operated.

6. **Raise** the load by turning the rotary switch on the cable control 1) to the upwards switch setting FOR RAISING 2). As soon as the rotary switch is released the winch will automatically stop.

7. **Lower** the load by turning the rotary switch on the cable control 1) to the downwards switch setting FOR LOWERING 2). As soon as the rotary switch is released the winch will automatically stop.

8. To **switch off** the winch return the key in the key switch back to a vertical position. The green signal lamp will go off if the current is turned off.



IMPORTANT!

The lift possesses two automatic limit switches that deactivate the rotary switch of the control system and automatically stops the winch immediately when the loading accessory has either reached its lowest position (when LOWERING) or its highest position (when RAISING).

Emergency release:

If the lift is malfunctioning it is crucial that the electric emergency release is deployed. It automatically lowers the winch and loading accessory and activates the red signal lamp 5). If there is a malfunction the winch and cable control system will not operate due to safety requirements. Call a service technician!

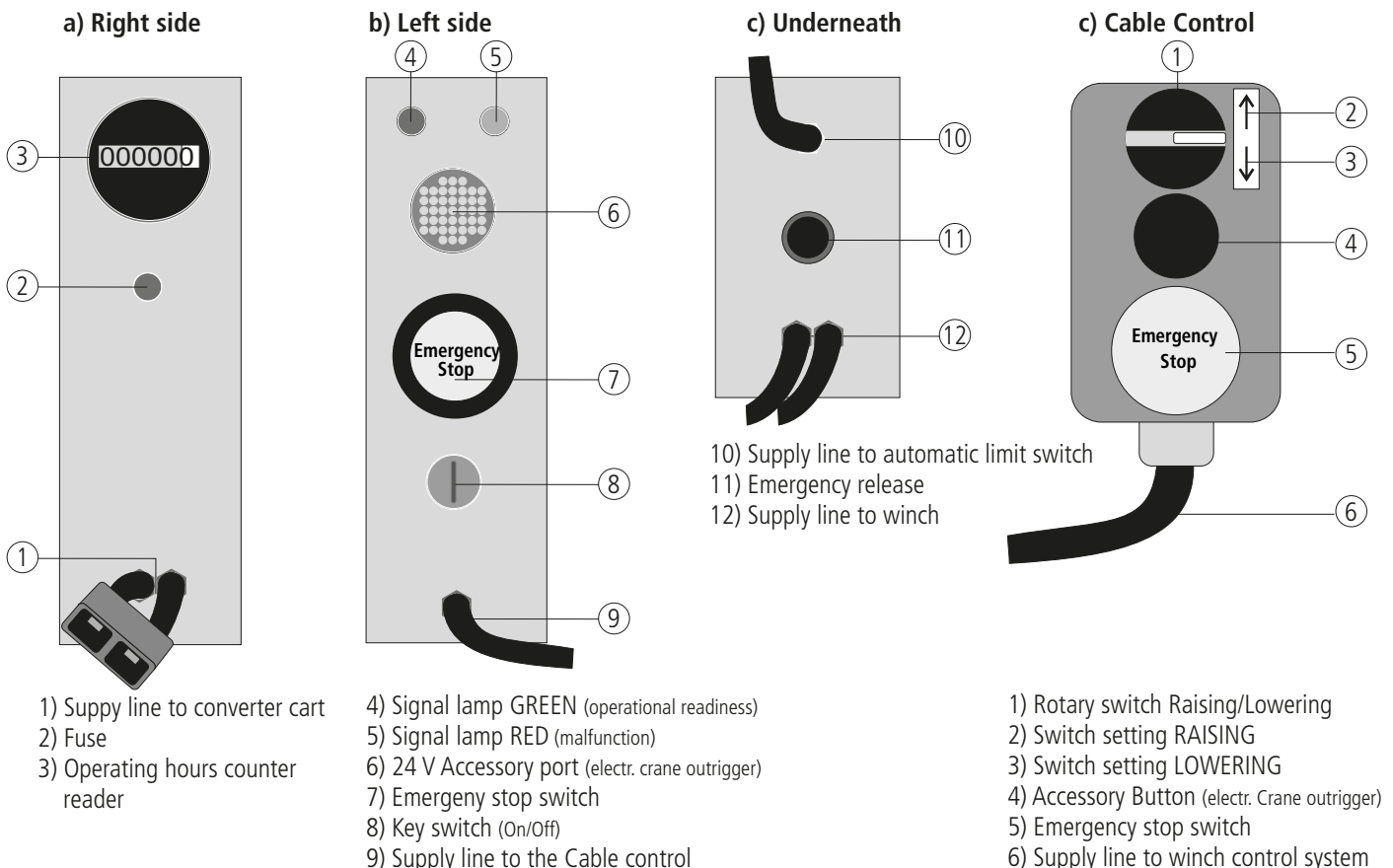

Loading and Transportation.

Preparation for transport.

Fundamentals

1. Preparation:

A: Uninstall the loading accessory. This allows for an economical and space-saving storage during transport.

B: Convert the lift from its operating position order! to its transport position.

2. Dismantling:

The loading accessory must be uninstalled before converting the lift to transport position.

Follow the steps for **Installation** in **reverse**

3. Varying Transport Positions:

There are one transport position for:

► Models with Converter Cart

The correct transport position does not depend on whether the model has an electric or manual winch.

Transport Position

GML500+/30 K DC

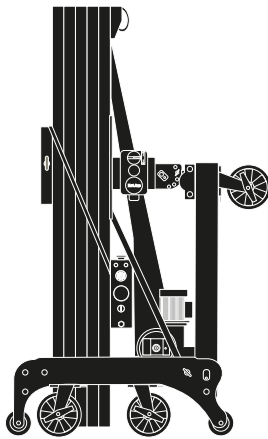

On models with counterweights (DC) the loading accessory **and** all other components, except for the structural elements, must be uninstalled before converting the lift to its transport position:

Components:

- 1) 1x Converter cart
- 2) 6 x 16 kg weights

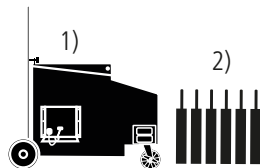

The loading accessory **and** components 1 - 2 must always be transported, secured and stored separately.

When necessary the counterweights may be stored in the weight box.

Take note: Gross weight ~ ca. 200 kg

Exceptions:

There are some occasions where a GML may be loaded without having been previously converted to its transport position.

In these exceptional cases the lift may be loaded when:

1. The ramp being used when moving the lift onto the transport vehicle or trailer possesses a sufficient width and provides a sufficient load bearing capacity.



WARNING:

On a ramp with a steep slope, the lift may roll backwards. Therefore the lift must always be pushed onto the loading surface by at least two people (preferably more).

2. The lift is equipped with the optionally available forklift receptors and can be safely loaded onto the transport vehicle or trailer with a forklift.



WARNING:

When the lift is loaded using the forklift receptors, loading must **always occur from the rear to avoid damage to the mast system.**



Always ensure that the forks on the loading forklift are inserted to an adequate depth in the forklift receptors on the GML lift.

Loading and Transportation.

Basic Procedures.

Before loading, familiarise yourself with the requirements for the loading methods as well as for the vehicles/trailers for lift transportation. Read and obey the respective conditions.

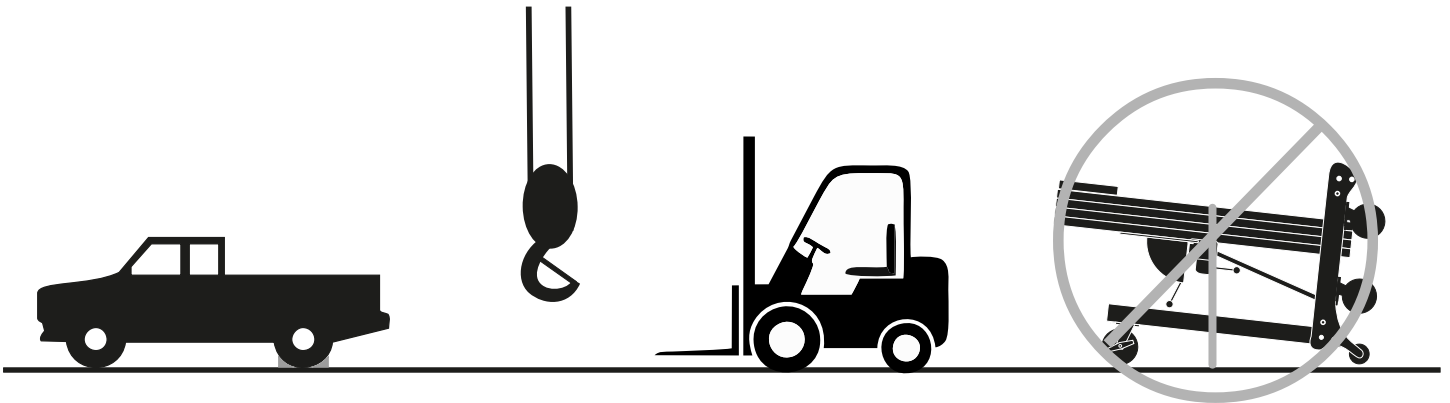

Transport vehicle/trailer:

1. The transport vehicle/trailer must be positioned on a firm, flat and level surface.
2. The transport vehicle/trailer must be appropriately secured to avoid rolling while the lift is loaded.
3. Ensure that the transport vehicle/trailer:
 - is big enough
 - has sufficient SWL/ towing capacity
 - has been provided with sufficient securing points.

Loading attachment:

1. When loading with a **crane/forklift** ensure that the lifting capacity of the crane/ forklift is sufficient in order to be able to load safely.
2. Ensure that the applied **belts/chains** for raising loads are without damage and have sufficient dimensions for the weight of the lift.
3. Take into account the weight specifications of the lift on the name plate of the chassis or/and the technical data within this operating manual.

Load safety:

1. The lift must be sufficiently secured by belts/chains when being transported.
2. Ensure that the applied belts/chains employed for safe loading are without damage and have sufficient dimensions.
3. Secure the lift properly and ensure that the belts/chains **DO NOT COME INTO CONTACT WITH THE MAST SYSTEM.**
4. Ensure that **the mast system is free of any obstructions and not put under strain by e.g. the belts/chains etc.**



Trailers with a ramp:

1. Follow steps 1-3 of the section 'Transport vehicle/Trailer'.
2. When using a ramp ensure that it
 - has sufficient load bearing capacity
 - is stable enough
 - cannot be bent/ruptured
 - is secured to avoid slipping

Loading and Transportation.

Loading while tilting.
Loading by crane.

Before loading, familiarise yourself with the requirements for the loading methods as well as for the vehicles/trailers for lift transportation. Read and obey the respective conditions.

1. Tilting

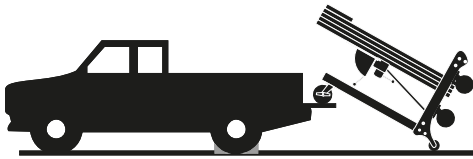

1. Place the lift in a tilted position ready to be loaded upon the vehicle for transportation.
2. Confirm that the mast system is in a lowered position and properly secured by the mast element transport safety hook. Examine the lift for any loose parts and make sure that the lateral outriggers (if equipped with) are secured and in a folded position.
3. Utilise the correct lifting methods to either load the lift onto the loading area or instead load it directly into the transport vehicle or trailer itself.
4. Engage the safety brakes on the casters that are in contact with the surface of the loading area.
5. Ensure that the lift is secured properly with the appropriate belts/chains in order to avoid any uncontrolled movements or any possibility of it tipping-over etc. Avoid damage to any lift components when securing it.

Unloading:

6. To unload the lift from its transport position loosen the belts/chains and disengage the safety brakes on the casters.
7. Push the lift carefully and slowly towards the edge of the vehicle's loading area.
8. Utilise the correct lifting methods to unload the lift from the transport vehicle or trailer directly onto the ground.

WARNING: When the lift is being set onto the ground ensure that you keep a safe distance from it! To not do so will increase the likelihood injuries being uncurrred.

2. Crane

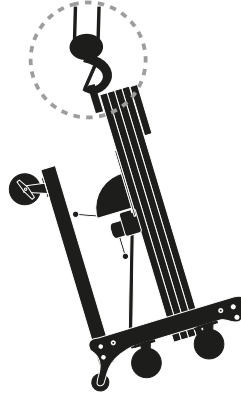

1. Place the lift in position for transportation under the hook of the crane.
2. Confirm that the mast system is in a lowered position and properly secured by the mast element transport safety hook. Examine the lift for any loose parts.
3. Ensure that the crane has sufficient lifting capacity.
4. Utilise the lifting hook of the crane for the prescribed hoisting ring of the lift only. The ring is located on the upper end of the mast system.
5. Clip the lifting hook of the crane onto the hoisting ring of the lift. Make sure that it is securly fastened before the lift is elevated.
6. Use the crane to carefully elevate the lift and position it onto the loading area as required.
7. Lower the lift carefully onto the ground and disconnect the crane from the lift.
8. Engage the safety brakes on the casters that are in contact with the surface of the loading area.
9. Ensure that the lift is secured properly with the appropriate belts/chains in order to avoid any uncontrolled movements or any possibility of it tipping-over etc. Avoid damage to any lift components when securing it.

Unloading:

1. To unload the lift from its transport position on the vehicle/trailer, loosen the belts/chains and then disengage the safety brakes on the casters.
2. Push the lift carefully and slowly to a position in which unhindered and safe access by crane is possible.
3. Clip the lifting hook of the crane onto the hoisting ring of the lift. Make sure that it is securly fastened before the lift is elevated.
4. Use the crane to carefully elevate the lift from the loading area of the vehicle/trailer and set it slowly down to the ground.
5. Disconnect the crane from the lift.



WARNING:

- > **When the lift is being set onto the ground ensure that you keep a safe distance from it!**
- > **Ensure that no one remains beneath the lift while it is being loaded or unloaded!**

Loading and Transportation.

Loading by forklift.

Only for models with (optionally available) forklift receptors.

Before loading, familiarise yourself with the requirements for the loading methods as well as for the vehicles/trailers for lift transportation. Read and obey the respective conditions.

3. Forklift

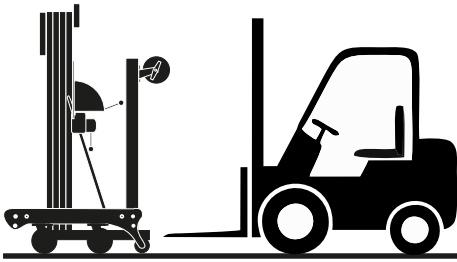

1. Place the lift in transport position in front of the forklift.
2. Confirm that the mast system is in a lowered position and properly secured by the mast element transport safety hook. Examine the lift for any loose parts and make sure that the lateral outriggers (if equipped with) are secured and in a folded position.
3. Ensure that the forklift has sufficient lifting capacity.
4. Adjust the forklift receptors by pulling out their locking pins.
5. Position the forklift carefully and slowly behind the lift and adjust the prongs of the forks to the forklift receptors. The adjustment and the elevation of the lift must always occur **from the rear** of the lift! Otherwise the mast element might be damaged.
6. After ensuring that the prongs of the forks and the receptors have been adjusted correctly, raise the lift carefully. Guarantee that the forks have been sufficiently inserted into the forklift receptors in order to avoid any danger of tipping-over while the lift is being raised.
7. Raise the lift carefully by using the forklift and position it above the desired loading area.
8. Lower the lift carefully onto the ground and remove the forks slowly.

9. Position the lift manually at the place required on the loading area.
10. Engage the safety brakes on the casters that are in contact with the surface of the loading area.
11. Ensure that the lift is secured properly with the appropriate belts/chains in order to avoid any uncontrolled movements or any possibility of it tipping-over etc. Avoid damage to any lift components when securing it.



Unloading:

1. To unload the lift from its transport position, loosen the belts/chains and then disengage the safety brakes on the casters.
2. Ensure that the forklift has sufficient lifting capacity.
3. Push the lift carefully and slowly to a position in which unhindered and safe access by forklift is possible.
4. Ensure that the lift is positioned to allow safe and easy access to the **rear side** of the lift by the forklift! Otherwise the mast element might be damaged.
5. If necessary adjust the forklift receptors by pulling out their locking pins.
6. Position the forklift carefully and slowly behind the lift and adjust the prongs of the forks to the forklift receptors.
7. To raise the lift carefully guarantee that the forks have been sufficiently inserted into the forklift receptors in order to avoid any danger of tipping-over while the lift is being raised.
8. Elevate the lift carefully from the loading area by using the forklift and then set it down slowly onto the ground.



WARNING:
Keep safe distance! The lift may tip from the forklift.

Loading and Transportation.

Movement onto the trailer.

Before loading, familiarise yourself with the requirements for the loading methods as well as for the vehicles/trailers for lift transportation. Read and obey the respective conditions.

4. Movement

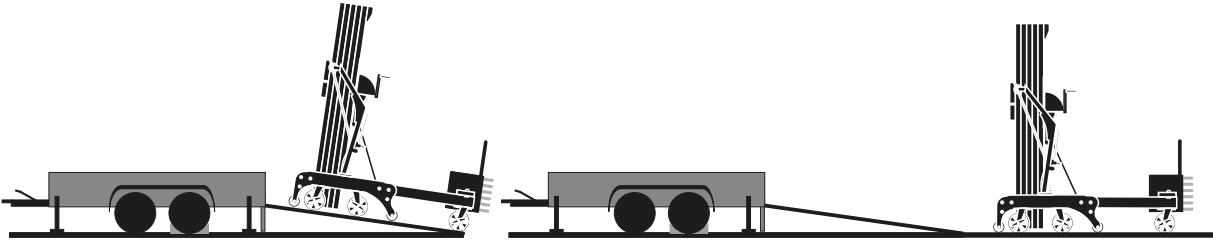

1. Place the lift in its transport position in front of the trailer. The trailer must be braced and its brake must be engaged securely. The wheels of the trailer must also be secured with wedges to prevent rolling.
2. Only move the lift onto the trailer if you can ensure that the ramp possesses sufficient load bearing capacity and stability as well as being adequately secured against slipping.
3. Confirm that the mast system is in a lowered position and properly secured by the mast element transport safety hook. Examine the lift for any loose parts and make sure that the lateral outriggers (if equipped with) are secured and in a folded position.
3. Move the lift with at least two or more people to be able to propel it up the ramp and onto the trailer.



WARNING:
The lift may roll backwards. If the lift is not secured against rolling, injuries may occur!

4. Position the lift manually at the place required on the loading area.
5. Engage the safety brakes on the casters that are in contact with the surface of the loading area.
6. Ensure that the lift is secured properly with the appropriate belts/chains in order to avoid any uncontrolled movements or any possibility of it tipping-over etc. Avoid damage to any lift components when securing it.

Unloading:

1. Ensure that you have enough space between the trailer and any possible obstructions nearby. The lift may roll uncontrollably backwards.
2. To unload the lift loosen the belts/chains and then disengage the safety brakes on the casters.
3. Move the lift carefully and slowly towards the place where the edge of the trailer meets the ramp. The ramp must possess sufficient load bearing capacity and stability as well as being adequately secured against slipping.
4. Secure the lift as far as possible to avoid it rolling down the ramp and thereby decreasing the risk of any accidents or injury.
5. If the lift is to be unloaded off the loading area by means of a ramp, make sure that at least two burly people are available to enable the lift to roll down in a controlled manner.
6. Let the lift move slowly down the ramp. At the moment it has left the ramp completely and is in contact with the level ground, it can then be released.



WARNING:
Ensure that you have enough space available near the trailer to enable you to evade the lift if it rolls uncontrollably backwards.

Technical Data

DC-series (24 Volt)	GML / 30 / K / DC
Lifting heights (standard fork on top):	8,80 m
Transport position - height / length / width:	1,99 / 1,44 / 0,81 m
Working position - height / length / width:	1,99 / 2,32 / 0,84 m*
Payload max. (load centre with 28 cm) :	500 kg
Own weight:	702 kg
Weight without attachment parts:	481 kg

* max. 2,80 m with lateral outriggers

Declaration of Conformity

EC declaration of conformity in accordance with Directive 2006/42/EG, appendix II 1.A (Original EC declaration of conformity)			
Norbert Wienold GmbH, Industriegebiet Waldstr. 35a, 48488 Emsbüren			
Make	Material- und Glaslift	Type and function	Lifting, lowering, holding and mounting loads
Model	GML 500 / 30		
Serial No.			
Year			

We hereby declare that the design, construction and production of the below listed material/glass lift comply with applicable health and safety requirements here the EC Machinery Directive 2006/42/EG.

OELGEMÖLLER Planning+Engineering
 Hessbergstraße 12
 48488 Emsbüren

- EC Directive
 Machinery Directive 2006/42/EG
 Low Voltage Directive 2006/95/EG
 Noise Emission Directive 2003/10/EG
- Applied harmonizing EN standards
 Cranes –General design – Part 1: General principles and requirements; DIN EN 13001-1
 Crane safety – General design – Part 2: Load conditions DIN EN 13001-2
 Cranes –Power driven winches and hoists – Part 1: Power driven winches; DIN EN 14492-1
 Cranes –Power driven winches and hoists – Part 2: Power driven hoists DIN EN 14492-2
 CE requirements EN 12100 of Machinery General design sets
- Instruction and compliance of conformity from our suppliers, for example, Motors , electrical etc.
- The special technical documents according to Annex VII · Part B and the assembly instructions in accordance with Annex VI to Directive 2006/42 / EC have been created . Compliance with the requirements according to the Low Voltage Directive , in accordance with Annex 1 , no. 1.5.1 of the Directive 2006/42 / EC ensured .

Representative of Norbert Wienold GmbH

	Identification of the signatory
Venue:	Emsbüren
date of issue:	
Function of the signatory within the company :	Managing director
Name of signatory:	Norbert Wienold
signature:	

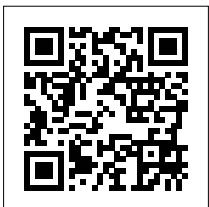

Norbert Wienold GmbH
Industriegebiet Waldstr. 35a
48488 Emsbüren
Germany

Tel. +49 59 03 - 93 94 0
Fax +49 59 03 - 93 94 50

www.wienold-lifte.de
e-mail: info@wienold-lifte.de

Rental stations and service facilities:

Emsbüren
Walsrode
Brandenburg
Leverkusen
München