

Operation Manual



Wienold Glass and Material Lift

GML 800+

GML 800+ /Std. /10, 15, 20, 25

GML 800+ /K /10, 15, 20, 25

Power options:

M [Manual Winch]

AC [230/110V Winch]

DC [24V Winch]

Contents

Contents	Page
Basic procedures	3
General description	4
GML Series typ overview	5
COMPONENTS VIEW	
GML800+/Std M	6
GML800+/K M	7
GML800+/K AC	8
GML800+/K DC	9
Electrical components	11
Safety instructions	13
Pre-operation inspection	19
Working area inspection	21
Function tests	22
Operating instructions	25
INSTALLATIONS	
GML800+/Std	26
GML800+/K (M+AC)	29
GML800+/DC	34
Lateral outrigger	35
Mast safety hook	36
Loading devices	37
Load preparation	38
RAISING/LOWERING LOADS	
by manual winch	40
by electric winch (AC Series, 220/110V)	41
by electric winch (DC Series, 24V)	42
Charging batteries at DC models	43
Loading/Transportation	44
Technical data	49
Declaration of conformity	50

Basic Procedures

Please read and comply with:



- The manufacturer's instructions and safety regulations.
- The operating and safety instructions for this lift.
- The inscriptions, labels and warning signs on this lift.
- The safety instructions and operating instructions at the job site.
- The current, local and legal safety regulations.

This lift fulfils the current CE regulations and norms, EN ISO 12100, as well as the machinery directive 2006/42/EG, when used and operated according to the manufacturer's recommendations.

It is the duty and responsibility of each operator to obey all regional rules and regulations concerning the safe usage of this lift.

Please read carefully and follow all of the safety instructions for this appliance before maintenance, repair or operation.

This is in compliance with all the manufacturer's recommendations and all of the legal guidelines as required by the government and local authorities.

In order to allow for a safe and appropriate use of this lift, it may only be used by persons who have been instructed by authorised specialists and who have been granted operative authorisation.

Repairs and maintenance of this lift are only to be undertaken by qualified and trained personnel without exception.

This lift is subject to an annual UVV-inspection by an authorised tester. Without a current UVV-test seal this lift must not be operated.

The owners and anyone hiring/borrowing this lift should have all construction parts undergo a complete inspection. All of the lift's functions must be thoroughly examined and inspected before sale or lease takes place. Damaged and malfunctioning parts must be repaired or replaced.

This operating manual is an essential requirement for all operators of this equipment. For this reason it must always remain in its appropriate place on the lift and always be readily available.

Norbert Wienold GmbH is constantly developing and improving this and other Wienold products. For this reason our appliances and products may be subject to modification without prior notice.

If you have any questions or queries, or if you notice any mistakes and/or deviations concerning the contents of this operating manual, please do not hesitate to contact us.

Contact: _____



Waldstr. 35a
D-48488 Emsbüren
Germany

Tel.: +49 5903 - 9394-0

Fax: +49 5903 - 9394-50

info@wienold-lifte.de

Wienold-LIFTE.de

General Description

GML800+ Wienold Glass and Material Lift

The GML800+ consists of a chassis and a mast element system. The lifting height is defined by the number of mast elements. The loading capacity is defined by both the model and the required lifting height.

There are various models with different lifting heights. All models extend the mast elements sequentially until the required working height is reached.

The various mast elements drive systems and their corresponding models are listed below:

- a) per Manual Winch (M Series)
- b) per 230V Electric Winch (AC Series)
- c) per 24V Winch(DC Sries)

The 24V Model includes a battery pack and a battery charger.

On AC and DC models, an automatic mast limit switch ensures an automatic deactivation of the lifting movement when the maximum lifting height has been reached and this switch also controls the cable tension when lowering.

The GML800+ is equipped with frontal outriggers which, depending on the model, may also be deployed as rear outriggers when used in combination with counterweights.

Different loading accessories are employed to raise, lower, hold and load up to the Safe Working Load (SWL). A lifting fork or a crane outrigger are generally available as loading accessories. These can be easily substituted.

Minor positioning of the lift during operation must always be done manually.

Transportation of persons with the lift is strictly prohibited!

Do not operate the lift in areas where an explosion hazard exists.



BEFORE USE ALWAYS please read and understand:

The safe working load (SWL) of all components must be checked before use.

The lowest SWL is always relevant!

Example 1:

Lift: 1763 lbs SWL max.

Boom: 992 lbs SWL max.

Suction Cups: 992 lbs SWL max.

= 992 lbs SWL max.

Always follow the instructions of the load capacity chart!

Example 2:

Lift: 1763 lbs SWL max.

Boom: 992 lbs SWL max.

Suction cups: 551 lbs SWL max.

= 551 lbs SWL max.

GML Series

GML800+ /Std M

Standard with manual winch

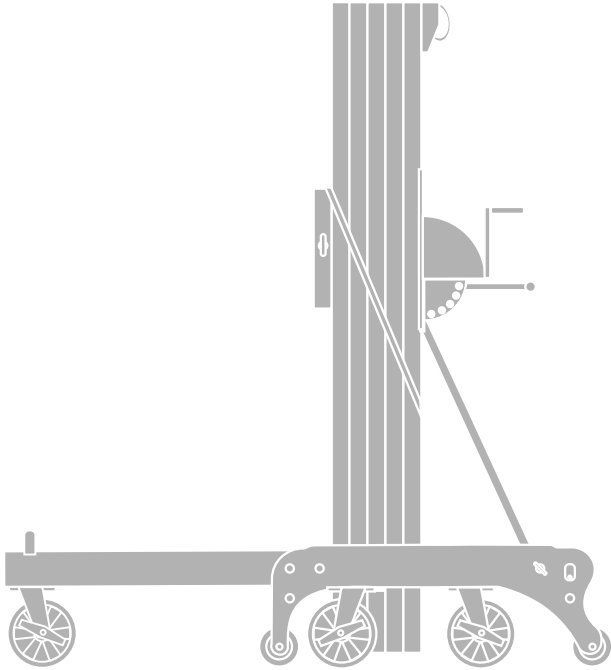

GML800+ /K M

with Counterweights and manual winch

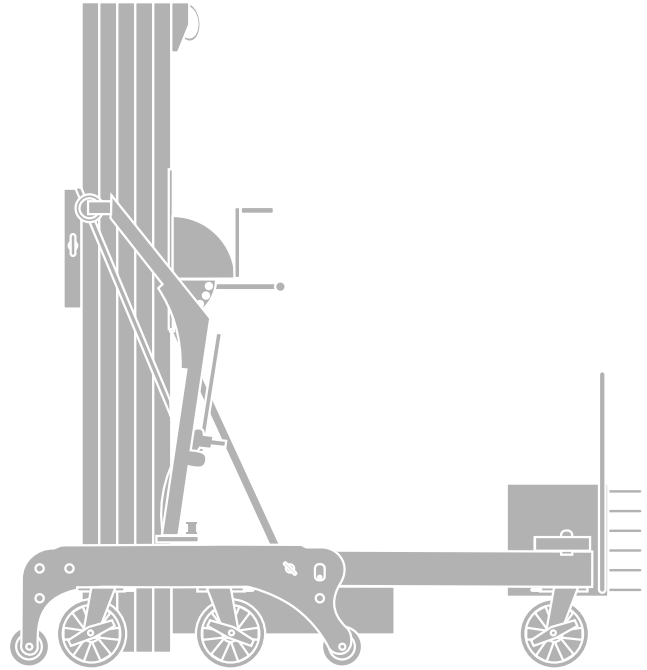

GML800+ /K AC

with counterweights and 230/110V winch

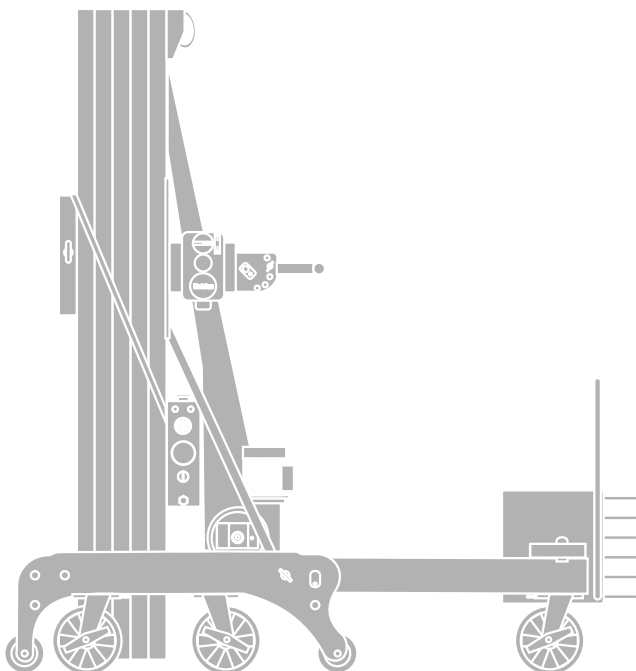

GML800+ /K DC

with counterweights and 12V winch

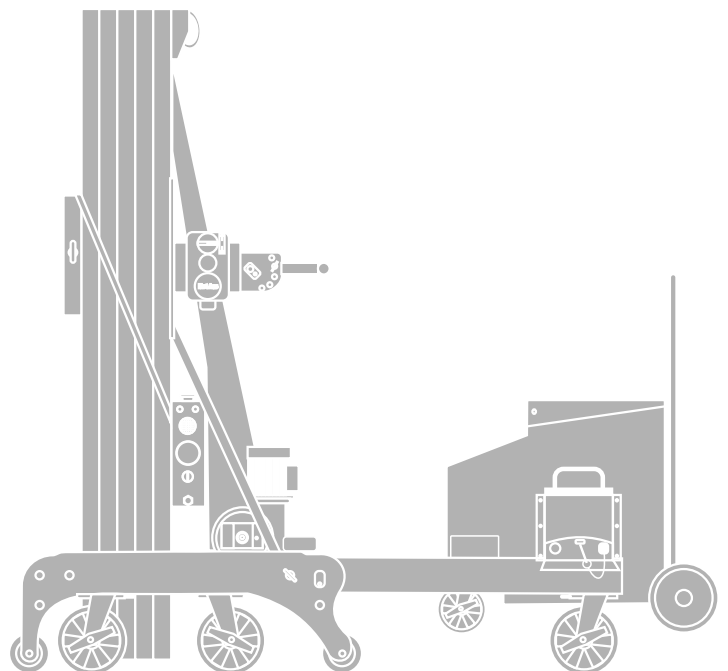

Components GML/Std M (Types GML /10 und /15)

Standard (Std) with maual worm winch (M).

Types GML /10 und /15 without lateral outriggers (as option available)
 Types GML /20 und /25 are equipped with lateral outriggers (standard).
 (ref. „Componets GML/K M“)

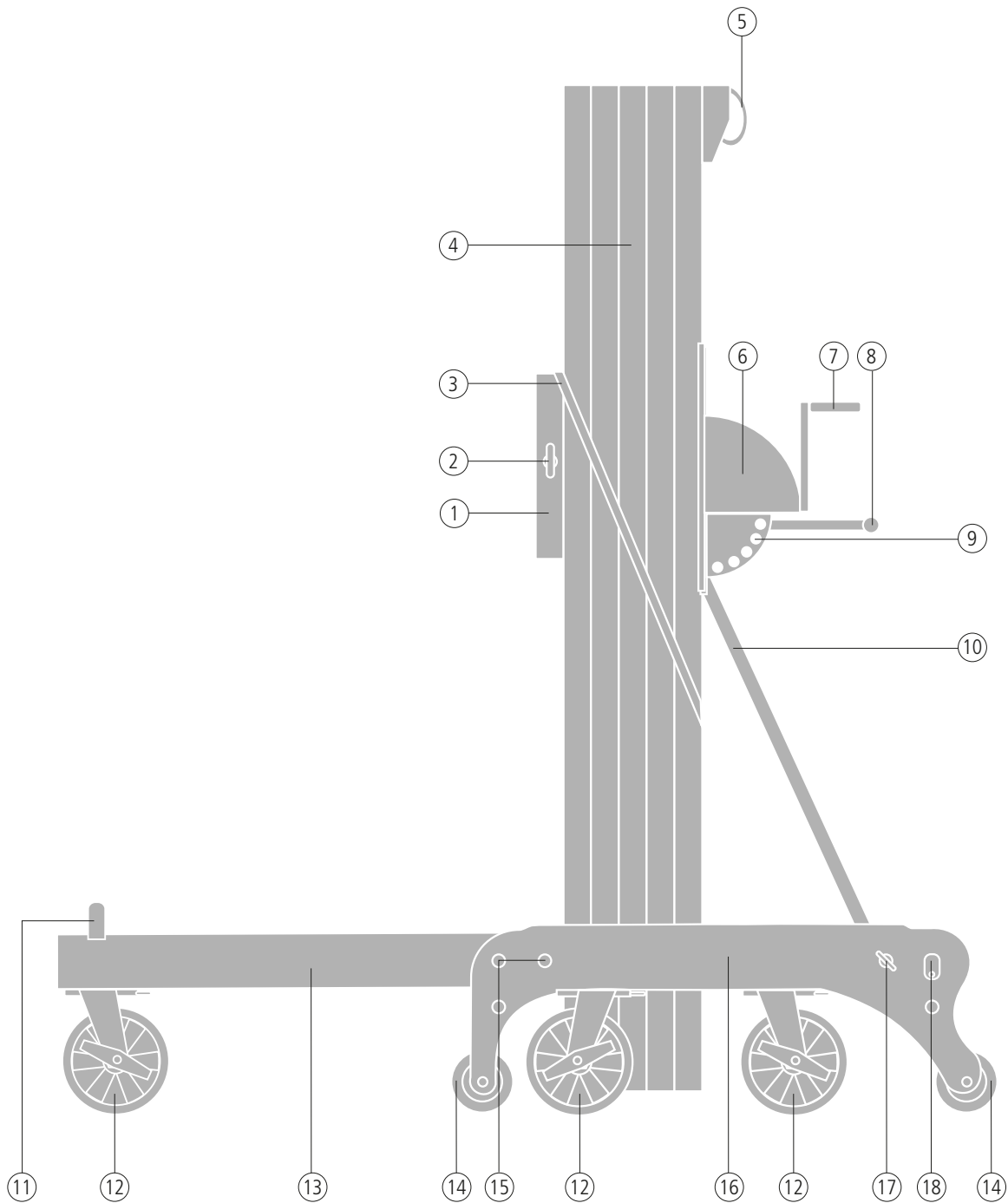

- | | | |
|--|----------------------------------|-------------------------|
| 1) Carriage | 8) Push bar | 15) Holes for outrigger |
| 2) Bolt to secure attachments | 9) Adjustment holes for push bar | 16) Chassis |
| 3) Hold down bar (for transportations) | 10) Stabilizer | 17) Securing pin |
| 4) Mast System | 11) Securing pin for weight box | 18) Bolt with nut |
| 5) Lifting eye | 12) Swivel caster with brake | |
| 6) Worm gear winch | 13) Outrigger | |
| 7) Worm winch crank | 14) Support wheel | |

Components GML/K M (Types GML /20 und /25 with lateral outrigger)

Series with counterweights (K) and manual worm winch (M).

- Fork lift pockets optional available for all models. -

Types GML /10 und /15 without lateral outriggers (as option available)

All Types GML /20 und /25 are equipped with lateral outriggers (standard).

Forlift Pockets 25 as option

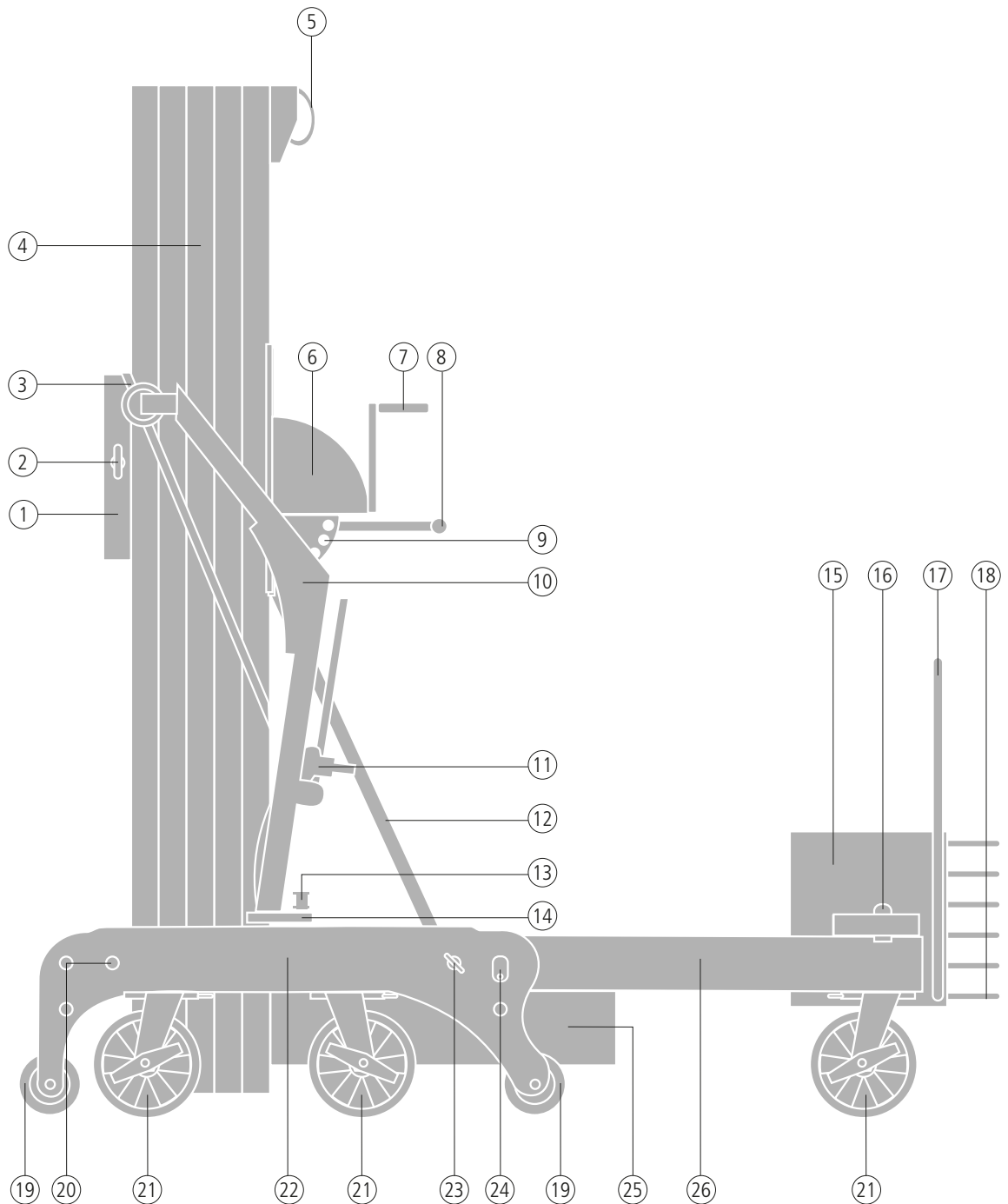

- 1) Carriage
- 2) Bolt to secure attachments
- 3) Hold down bar (for transportations)
- 4) Mast System
- 5) Lifting eye
- 6) Worm winch
- 7) Worm winch crank
- 8) Push bar
- 9) Adjustment holes for push bar

- 10) Lateral outrigger (Pair)
- 11) Lateral outrigger brake plate
- 12) Stabilizer
- 13) Lateral outrigger lock pin
- 14) Lateral outrigger adjustment plate
- 15) Counterweight box
- 16) Counterweight securing pin
- 17) Steering arm
- 18) Counterweights (2x 6 pcs.)

- 19) Support wheel
- 20) Holes for outrigger
- 21) Swivel caster with brake
- 22) Chassis
- 23) Securing pin
- 24) Bolt with nut
- 25) Forklift pockets (Option)
- 26) Outrigger

Components GML/K AC (Types GML /10 und /15)

With counterweights (K) and electrical 220/110V winch (AC).

Types GML /10 und /15 without lateral outriggers (as option available)
 All Types GML /20 und /25 are equipped with lateral outriggers (standard).
 (ref. „Componets GML/K M“)

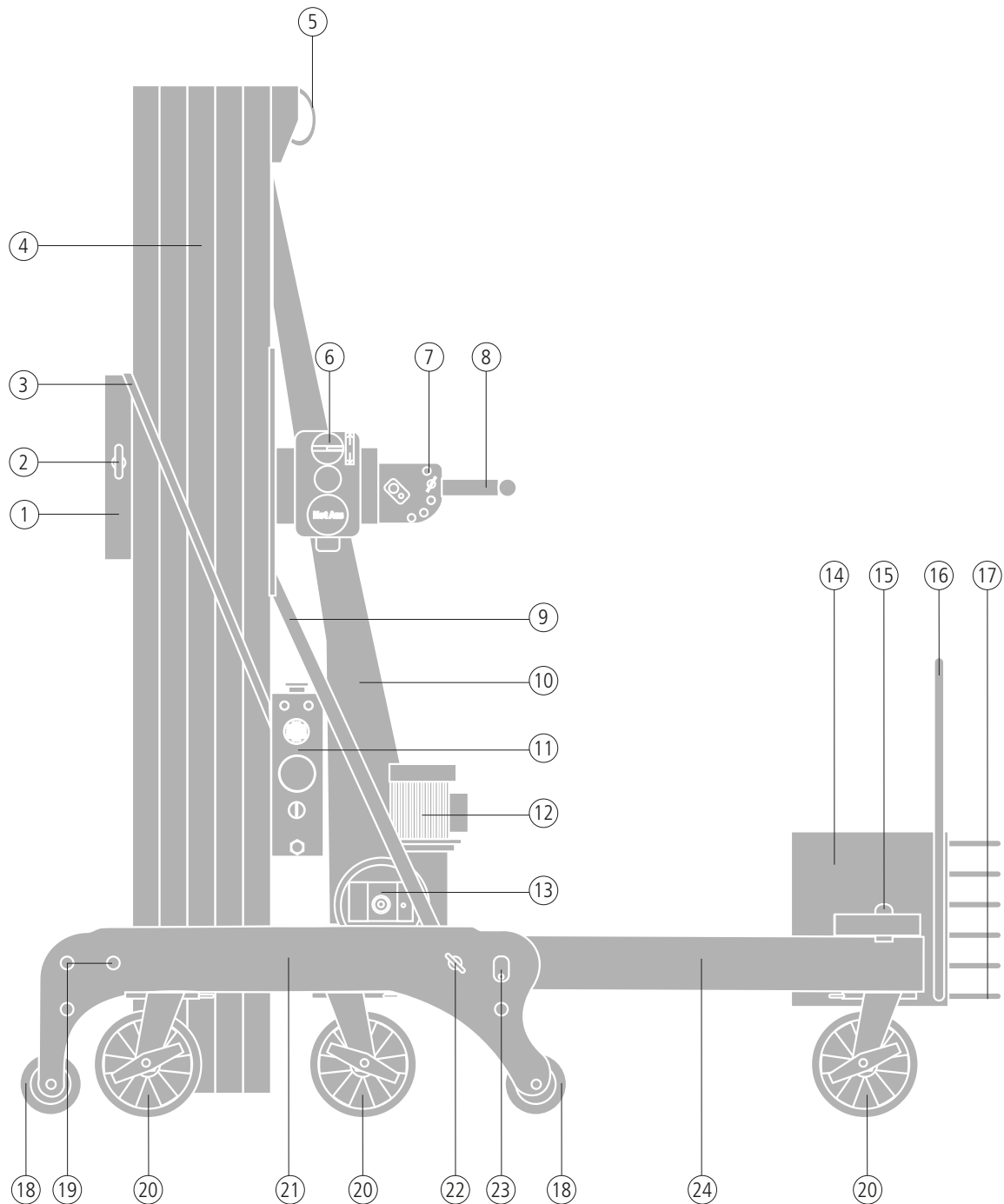

- 1) Carriage
- 2) Bolt to secure attachments
- 3) Hold down bar (for transportations)
- 4) Mast System
- 5) Lifting eye
- 6) Worm winch
- 7) Worm winch crank
- 8) Push bar

- 9) Stabilizer
- 10) Cable cover
- 11) Electric control box
- 12) Electric motor
- 13) Winch unit
- 14) Counterweight box
- 15) Counterweight securing pin
- 16) Steering arm

- 17) Counterweights (2x 6 pcs.)
- 18) Support wheel
- 19) Holes for outrigger
- 20) Swivel caster with brake
- 21) Chassis
- 22) Securing pin
- 23) Bolt with nut
- 24) Outrigger

Components GML/K DC (Typen GML /10 und /15)

With counterweights (K) and electrical 24V winch (DC).

Types GML /10 und /15 without lateral outriggers (as option available)
 All Types GML /20 und /25 are equipped with lateral outriggers (standard).
 (ref. „Componets GML/K M“)

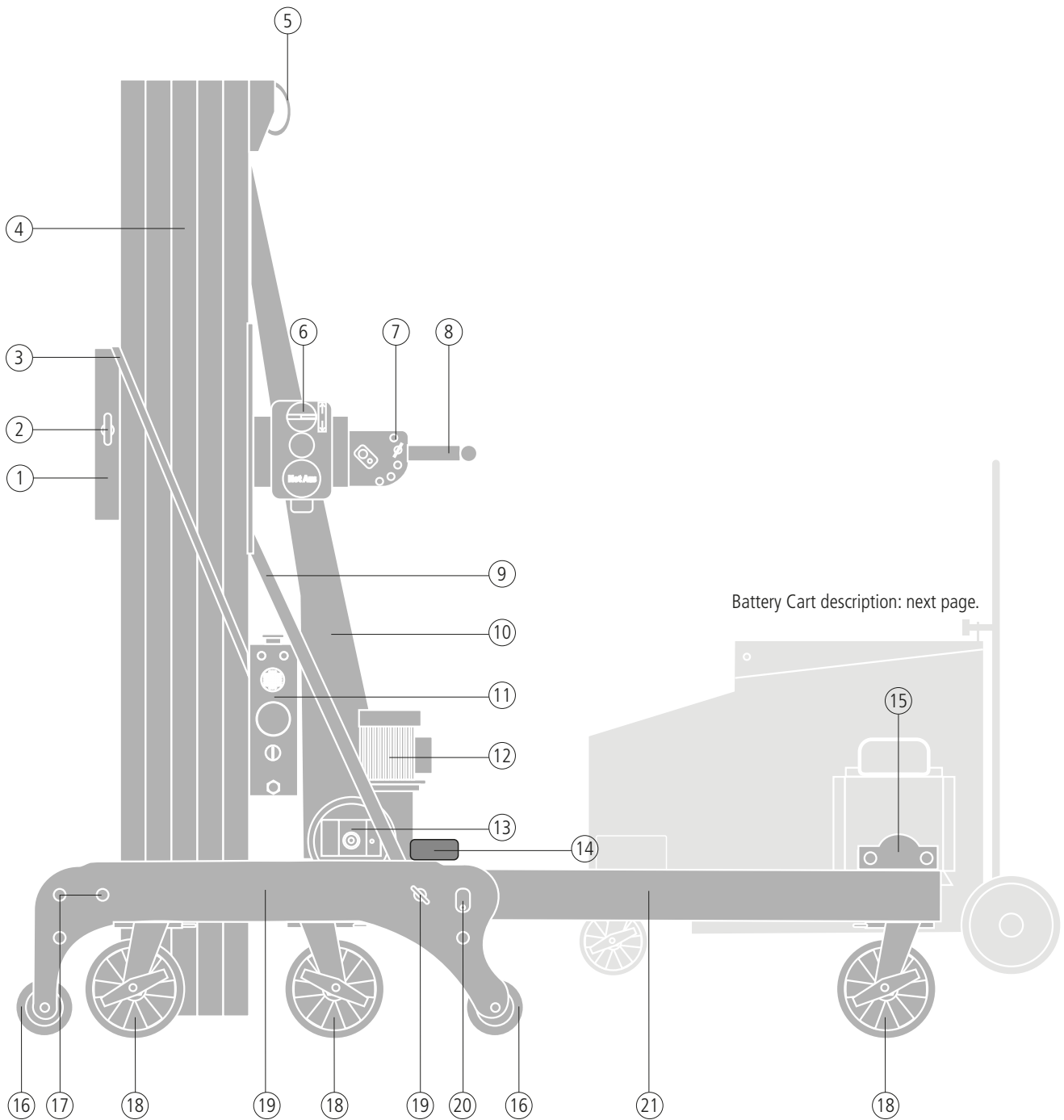

Battery Cart description: next page.

- | | | |
|--|------------------------------|------------------------------|
| 1) Carriage | 9) Stabilizer | 17) Holes for outrigger |
| 2) Bolt to secure attachments | 10) Cable cover | 18) Swivel caster with brake |
| 3) Hold down bar (for transportations) | 11) Electric control box | 19) Chassis |
| 4) Mast System | 12) Electric motor | 20) Securing pin |
| 5) Lifting eye | 13) Winch unit | 21) Outrigger |
| 6) Cable remote control | 14) Power supply | |
| 7) Push bar adjustment holes | 15) Slip-On for battery cart | |
| 8) Push bar | 16) Support wheel | |

Battery Cart GML/K DC (Types GML /10, 15, 20, 25)

With counterweights (K) and electrical 24V winch (DC).

Battery Cart includes batteries, charger, voltmeter, power switch, counterweights.

Left side:

Right side:

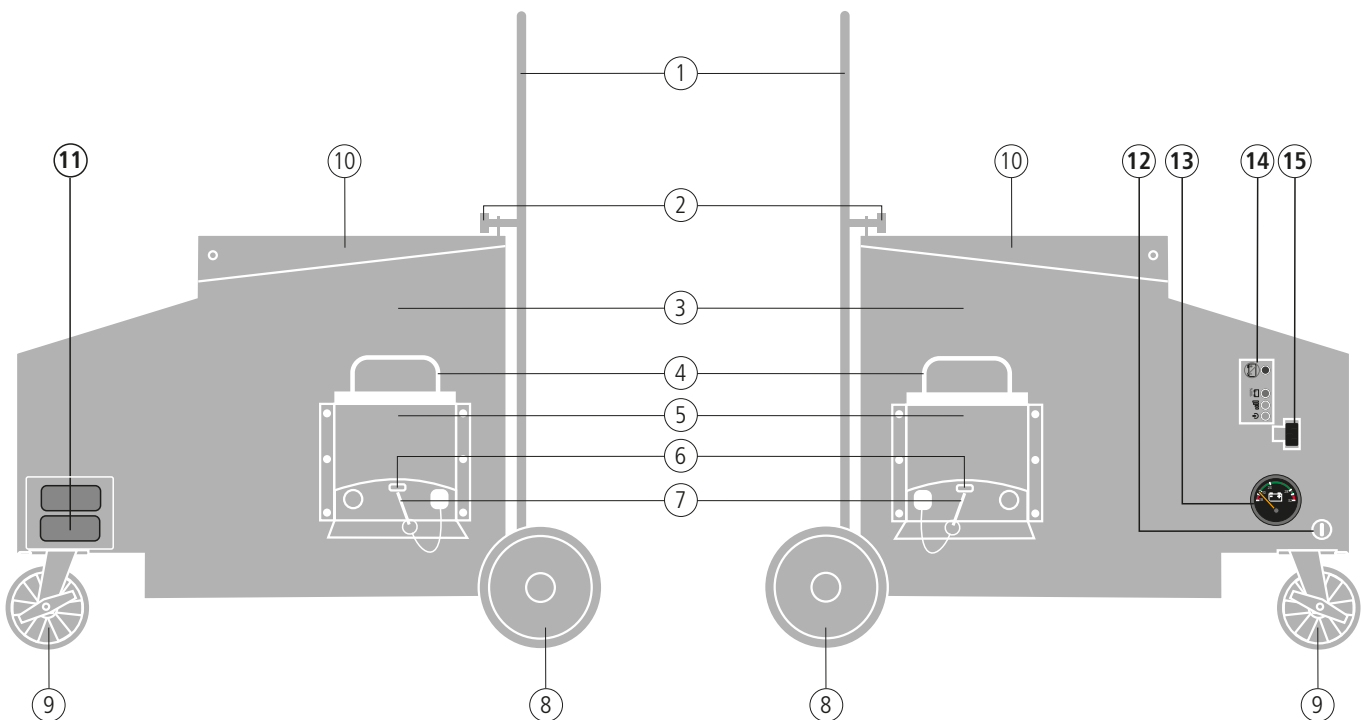

Left side:

11) Battery supply

Both sides:

- 1) Push bar
- 2) Battery pack locking
- 3) Battery pack
- 4) Counterweights (3 pcs. each side)
- 5) Counterweight box (screwed)
- 6) Slip-On eye for Securing pin
- 7) Slip-On securing pin
- 8) Caster
- 9) Swivel caster with brake
- 10) Battery access

Right side:

- 12) Power switch
- 13) Voltmeter
- 14) Charger with charge indicator
- 15) Charger supply

Electric Components AC-Series

Control box and cable remote control.

Control box left side:

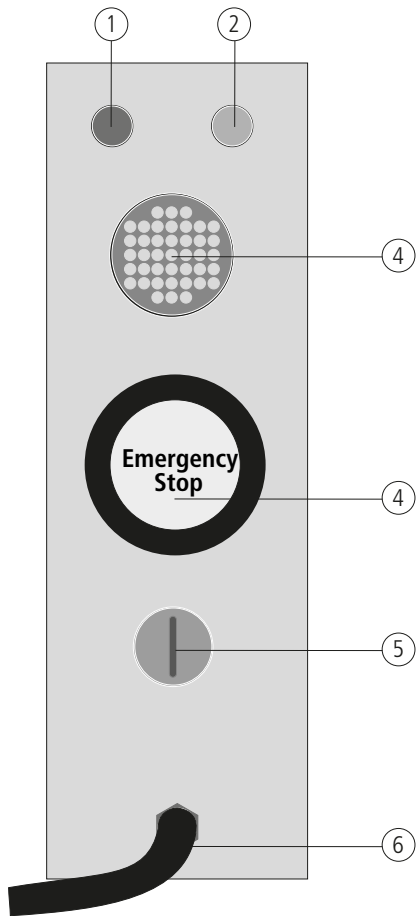

- 1) Green LED: ready to operate
- 2) Red LED: electrical interference
- 3) 24V socket for electrical attachments
- 4) Emergency Stop
- 5) Power switch (On/Off)
- 6) Cable remote control supply

Control box right side:

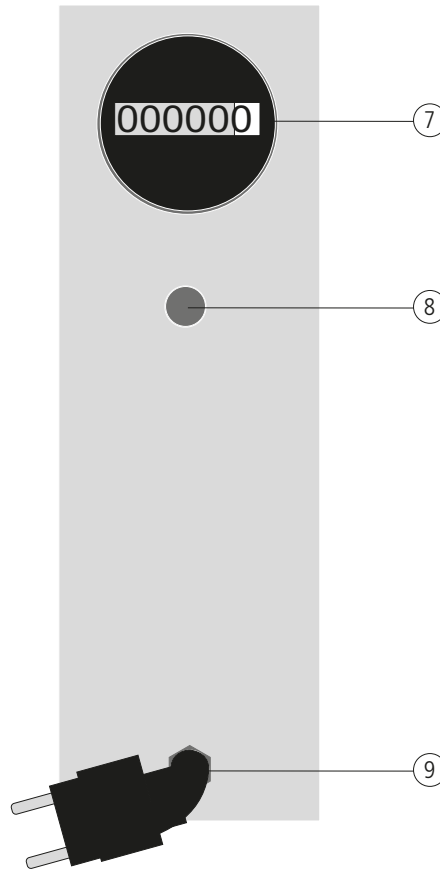

- 7) Hour meter
- 8) Fuse
- 9) 230/110V supply

Control box bottom side:

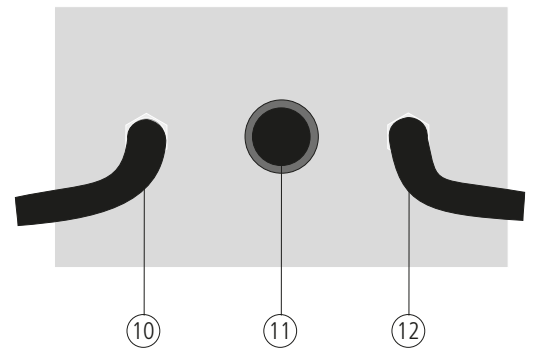

- 10) Limit switch supply
- 11) Emergency descent
- 12) Winch supply

Cable remote control:

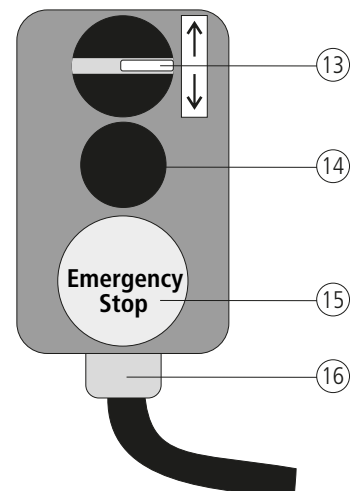

- 13) Switch UP/DOWN
- 14) Accessory control
- 15) Emergency Stop
- 16) Control box supply

Electric Components DC-Series

Control box and cable remote control.

Control box left side:

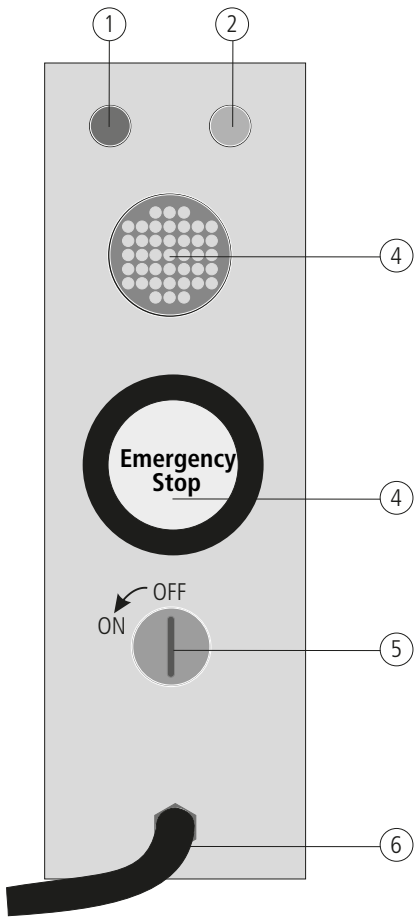

- 1) Green LED: ready to operate
- 2) Red LED: electrical interference
- 3) 24V socket for electrical attachments
- 4) Emergency Stop
- 5) Power switch (On/Off)
- 6) Cable remote control supply

Control box right side:

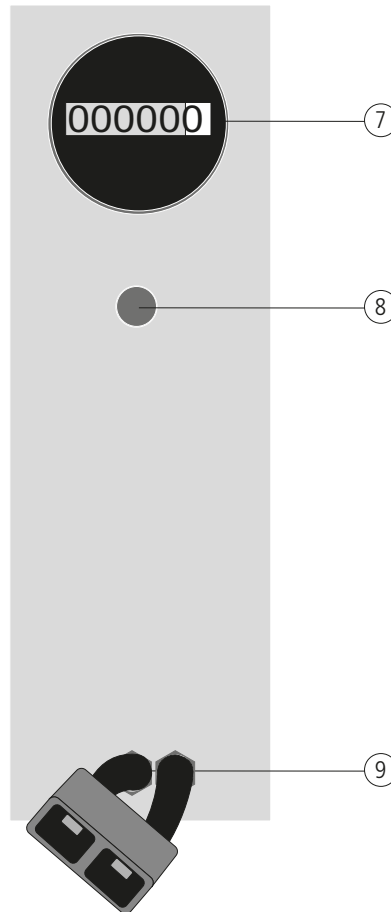

- 7) Hour meter
- 8) Fuse
- 9) Battery supply

Control box bottom side:

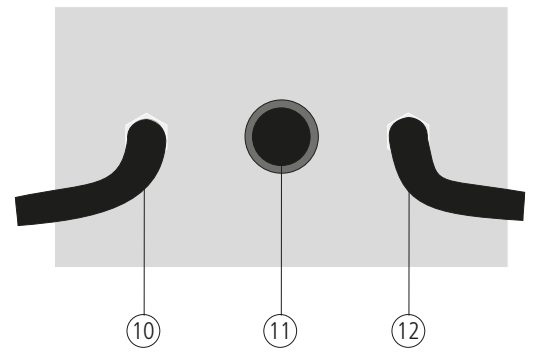

- 10) Limit switch supply
- 11) Emergency descent
- 12) Winch supply

Cable remote control:

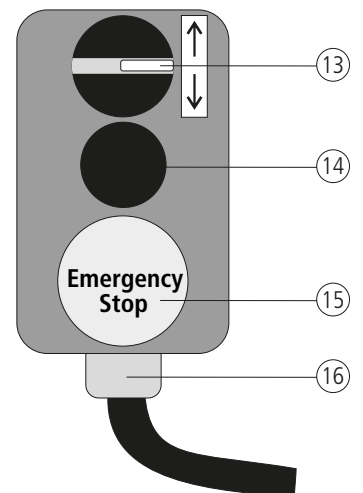

- 13) Switch UP/DOWN
- 14) Accessory control
- 15) Emergency Stop
- 16) Control box supply

Safety Instructions



Warning!

Failure to obey the instructions and safety regulations in this manual may result in death or serious injury.

Do Not Operate Unless:

- The personnel have been trained on this type of unit and are deemed competent. All operators should read the operating manual carefully.

1. Avoid hazardous situations.

Know and understand the safety regulations before going on to the next section.

2. Always perform a pre-operation inspection on the lift.
3. Inspect the working area thoroughly before using the lift.
4. Always perform the function test as per the operating manual prior to use.
5. Only use the lift as per the operating instructions. Any deviations are not acceptable. In case, you must always contact the owner of the equipment.

Read, understand and obey:



- a) the manufacturer's instructions and safety instructions.
- b) the operating manuals and safety instructions for the lift.
- c) the inscriptions, labels and warning signs on the lift.
- d) the safety instructions and work procedures on the job site.
- e) the relevant legislation in force for the equipment in use.

Safety Instructions

Wear Appropriate Personal Protective Equipment (PPE)

Always wear PPE before operating the lift including:

1. Safety helmets
2. Safety goggles
3. Safety shoes

Always check which PPE is required at each particular job site. Do not use the lift and do not execute any function tests without wearing the appropriate PPE.

Keep loose clothes, jewelry, hair etc. away from any moving parts and ensure appropriate PPE is worn whilst operating the unit. Keep hands and feet within the areas acceptable to operate the winch safely to raise or lower the unit.

Fall Hazards

Do not use this lift as a personnel lifting platform or step. Do not stand on the loading accessories (e.g. lifting fork etc.). Do not climb on the mast, the chassis or other components.

Tip-over hazards

Always ensure before either loading or lifting that the lift is positioned on a secure, solid, flat and horizontal subsurface.

Do not raise the load until all the available stabilisers and legs have been fully lowered and secured and the casters are in full contact with the work surface.

Do not raise the load until all outriggers are extended and the appropriate leg retainer pins are properly inserted into the chassis.

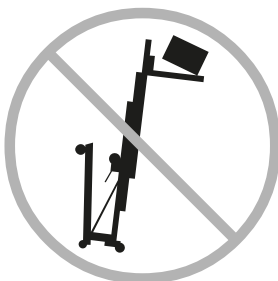

When using models with counterweights, only raise the load when the weight box has been completely filled with the specified counterweights.

A fixed and secured outrigger must not be re-adjusted as long as the lift is loaded or is in a raised position.

Prior to use, check the working area for steep slopes & drop-offs, holes and debris. Also check for instable, slippery or icy surfaces and other possible sources of danger.

Do not raise the load unless the loading accessories are correctly secured to the lift.

Do not use any blocks, stones, planks or any other items to balance the lift.

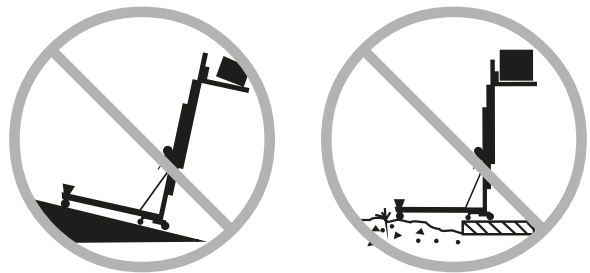

Do **not** move the lift with a raised load except for **very** minor positioning.

Never operate the lift if it is iced.

Never operate the lift in strong or gusty wind conditions. An increase in the load surface area will decrease lift stability when operating in windy conditions.

Never leave a load in a raised position when windy conditions may occur unless the lift is correctly tag lined.

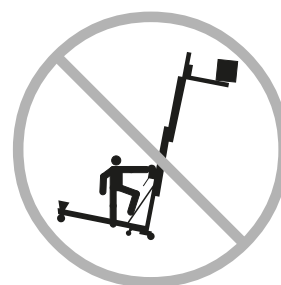

Always ensure, when raising or lowering secured or overhanging loads, that no obstructions can interfere with the safe operation of the lift.

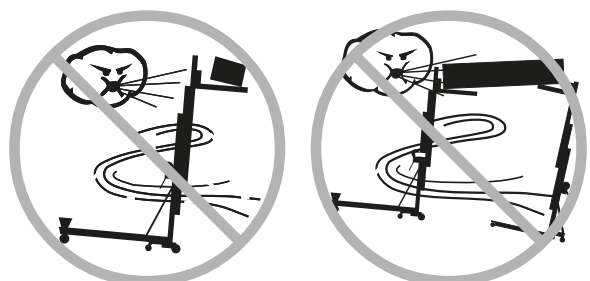

Safety Instructions

Electrocution Hazards - Danger to Life

This lift is not electrically insulated and will not provide protection from contact with or proximity to electrical current.

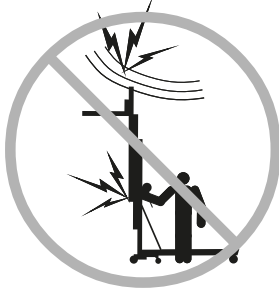

Keep away from the lift if it contacts electrical power cables. Personnel must not touch or operate the lift until the power conductors have been switched off.

Maintain safe distances away from electrical power conductors and appliances.

Please take into account the relevant current legal regulations and the following chart:

VOLTAGE	MINIMUM SAFETY DISTANCE
Phase-to-Phase	inch
0 - 300 V	Avoid Contact
300 V - 50 kV	122 in
50 kV - 200 kV	181 in
200 kV - 350 kV	240 in
350 kV - 500 kV	299 in
500 kV - 7550 kV	421 in
750 kV - 1000 kV	539 in

Allow for mast movement and possible swaying and sagging of electrical cables. Be especially careful in strong or gusty wind conditions!

The unit is not to be used in conjunction with welding units fitted to the forks under any circumstances..

Injury Hazard

Do not hold on the winch cable and do not grasp into the winch itself.

Do not lean any ladders or scaffolding against the lift or the load.



Do not operate the lift on a movable/mobile surface or on a motor vehicle.

The Safe Working Load (SWL) must not be exceeded under any circumstances. Always refer to the load charts on the unit.

Avoid moving the lift with closed outriggers over debris or uneven ground.

Never replace lift parts that are important for stability or construction with parts with different weights and specifications. Only use original replacement parts. If the equipment is damaged or operating incorrectly you must contact the hirer immediately.

Only use the approved loading accessories with this lift.

Lifting Hazards

Always use the correct lifting techniques when loading or tilting the lift. Personnel should be trained and competent to use the unit correctly.

Always use the correct lifting techniques when installing and de-installing the loading accessories.

Operating the Lift

Ensure that the safety brakes are engaged prior to operating the lift in order to avoid rolling.

Do not ever stand or allow others to stand under the loading accessories.

Always remain behind the winch when raising or lowering. Do not stand on the chassis, the outriggers or any other components.

Safety Instructions

Crushing Hazards

Do not raise if the load is not

1. correctly centred on the loading accessory.
2. correctly secured to the loading accessory.

Never stand under the load as it is being raised or lowered or suspended. Do not allow others to stand in the lifting area when the unit is being operated.



Standing under the load is prohibited. The load may fall from between 11 and 35 inch before the safety brake mechanism activates the locking of the mast elements.

Do not lower the load unless the area below is clear of personnel and obstructions.

Keep hands and fingers away from the winch, the folding outriggers, loading accessories and any other potential pinch points.

Maintain a firm grasp on the loading accessory when the safety bolt is removed. Otherwise the loading accessory will fall.

Maintain a firm grasp on the outrigger when the safety bolt is removed. Otherwise the outrigger will fall.

Maintain a firm grasp on the winch crank handle. The winch brakes engage automatically when you stop winding. The crank handle must not move when you stop winding.

Standard Forks

Only use appropriate loading accessories when lifting a load. Always ensure before loading that the loading accessory used is suitable for the load and is correctly secured.

Only raise the load when the loading accessory has been correctly installed and the load has been correctly aligned and secured. Always take into account the relation between lifting height and load center .

Collision Hazards

Check the working area for overhead obstructions or other potential sources of danger.

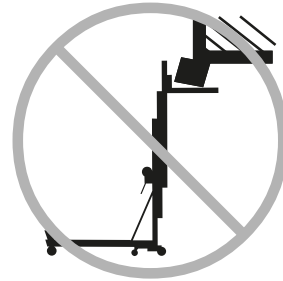

Always plan your route if transporting a load on site using the unit. Avoid sharp turns, inclines or voids in the ground. Only move the lift when in transport position!

Loading

When loading the lift (for transport), always ensure that the lift and the transport vehicle are on an even subsurface.

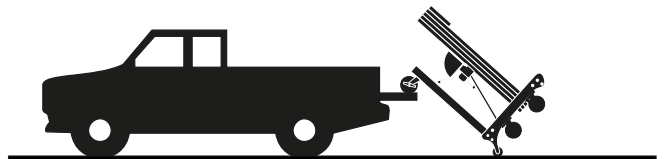

Always use the correct lifting techniques and always use the snap hook on top of the lift when using a crane or the forklift receptors when loading with a forklift.

Safety Instructions

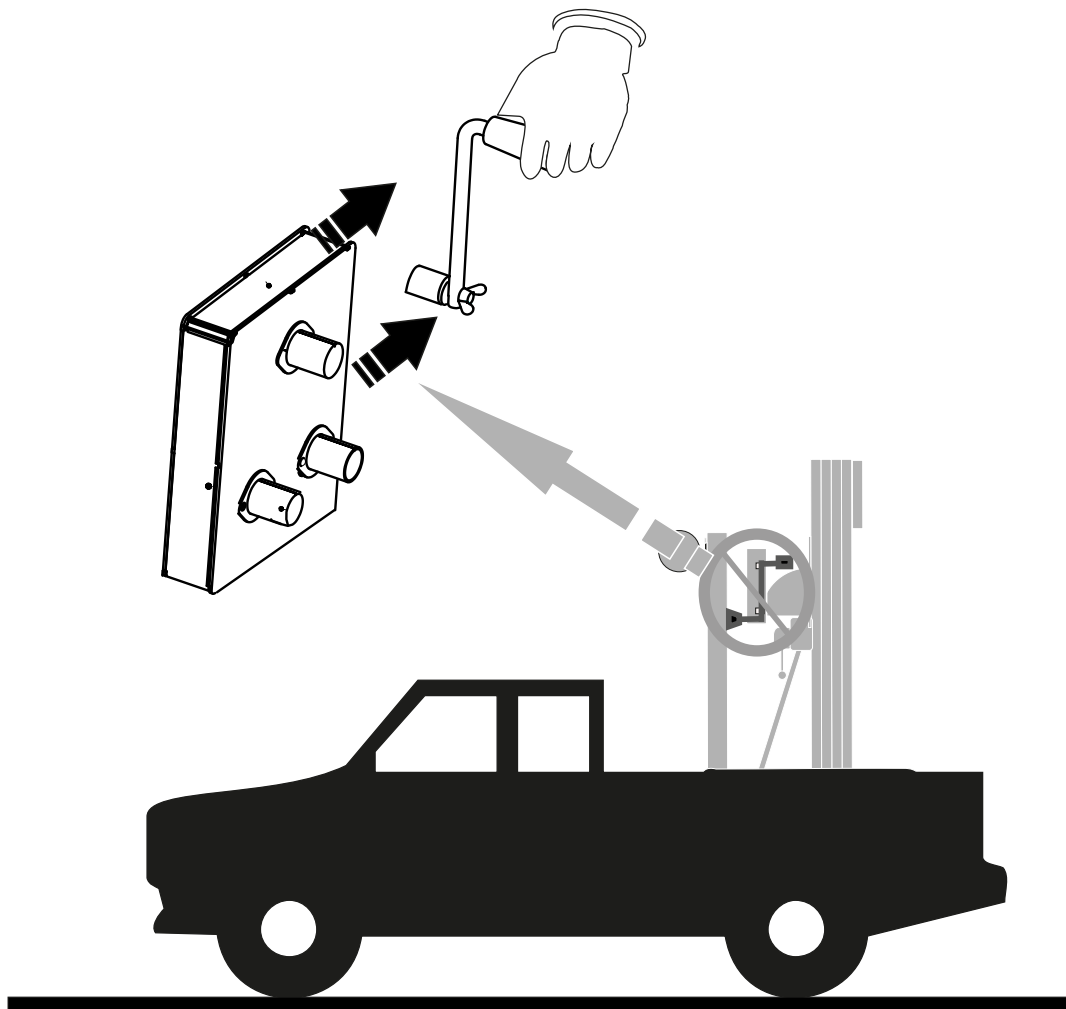

RISK OF FALLING DOWN

Dismount the handle for transportation by road, sea or air and store it in your vehicle. Otherwise there is a risk that the handle may come loose and fall down. Only move the lift with the handle stored on the 3-step drill kit when there is no risk that the falling handle could impute loss of life, physical injury or damage to health.

Safety Instructions

Damaged Lift Hazards

Do not operate a damaged or malfunctioning lift.

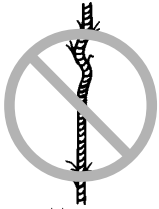

Do not use a lift with a worn, frayed, kinked or damaged cable.

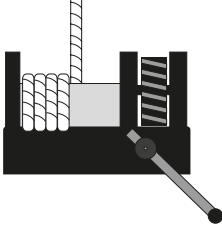

Do not use a lift with less than 4 layers of cable on the winch drum when the loading accessory is fully lowered.

Always conduct a thorough pre-operation inspection prior to each use.

Any damage, faults or failure of the unit must be assessed by a competent person trained to identify such matters and instructed for repair work on this lift. Non-appliance to this rule may lead to serious injury and possible danger to life.

Always ensure that all warning signs are legible and in place.

Always ensure that the operating manual is complete, legible and placed in the storage container installed on the lift.

Maintain proper lubrication on the winch. Do not allow oil or grease on the brake surfaces or on the mast elements.

Only use silicon spray when lubricating the mast elements (no oil or grease). Avoid spraying onto the brake surfaces.

Hazard due to improper use

Never leave a loaded lift unattended or suspended. Unauthorised personnel may attempt to operate the lift without having been correctly briefed and thereby create an unsafe situation.

Legend - Warning Signs

Wienold lifts, appliances & machines use symbols, colour codes and signal words to identify the following:



Safety Alert Symbol:

This is used to alert personnel to potential injury hazards. Obey all safety messages that follow this symbol to avoid possible injury or death.



RED = DANGER

This is used to indicate the presence of an imminently hazardous situation which, if not avoided, will result in death or serious injury.



ORANGE = WARNING

This is used to indicate the presence of a potentially hazardous situation which, if not avoided, could result in death or serious injury.



YELLOW = CAUTION

This is used to indicate the presence of a potentially hazardous situation which, if not avoided, may cause property damage or could result in death or serious injury..

Pre-operation Inspection



Non compliance with the instructions and safety rules in this operating manual may result in serious injury or accidents including death!

Do not operate the lift unless :

The personnel have been trained on this type of unit and are deemed competent. All operators should read the operating manual carefully.

1. Avoid hazardous situations.

Know and understand the safety regulations before going on to the next section.

2. Always perform a pre-operation inspection on the lift.

3. Inspect the working area thoroughly before using the lift.

4. Always perform the function test as per the operating manual prior to use.

5. Only use the lift as per the operating instructions. Any deviations are not acceptable. In case, you must always contact the owner of the equipment.

Fundamentals

The pre-operation inspection is a visual inspection which must always be performed by the operator prior to each work assignment.

This inspection is designed to identify and avoid possible malfunctions of the lift before the operator tests it.

Check the lift for modifications, damages and loose or missing parts.

A malfunctioning or modified lift must not be operated under any circumstances.

If any damage or unauthorised deviation from factory delivered condition is discovered, the lift must be removed from service and appropriately tagged. Additionally, the owner of the equipment must be informed.

Repairs to the lift may only be undertaken by a qualified service technician in compliance with the manufacturer's specifications.

The operator must perform a new pre-operation inspection after any repairs are completed, before going on to the function tests.



Read, understand and obey:

- a) the manufacturer's instructions and safety instructions.
- b) the operating manuals and safety instructions for the lift.
- c) the inscriptions, labels and warning signs on the lift.
- d) the safety instructions and work procedures on the job site.
- e) the relevant legislation in force for the equipment in use.

Pre-operation Inspection

Please ensure

that the operating manual is complete, legible and placed in the storage container installed on the lift.

Please ensure

that all warning signs and labels are both legible and correctly positioned. For further information see **Warning Signs** section.

Check

the following components and areas for damage, modifications, and incorrectly installed or missing parts.

- Chassis and base components
- Outriggers, support legs and stabilisers
- Wheels and tyres
- Mast elements and components
- Casters and swivel casters
- Winch, cable, cable anchor, pulleys
- Loading carriage including safety bolts and loading accessories
- Mast element transport safety hook
- Bolts, pins, screws and nuts
- Other fastening and safety devices

Check the entire lift and loading devices for:

- Bents or damage
- Corrosion or rust
- Cracks in welds or structural components
- Defects on the winch/cable

Please ensure

1. that all structural and other corresponding components such as fasteners, pins, bolts and locks are correctly installed and undamaged. Also ensure that the brakes on the lift are engaged and that the lift is in a safe position.
2. that the lift has a minimum of 4 layers of cable on the winch drum when the loading accessory is fully lowered.

AC and DC Machines

In addition to the checks of lifts with a manual winch, when using electrical or battery operated lifts the following inspections must be undertaken:

Function tests for :

- Automatic mast limit switch (on 230V and 12V models)
- All control elements
- All switches
- Electric winch
- Cables/cable connections and power outlets
- Batteries and battery charger (DC-series only)

Working Area Inspection



Non compliance with the instructions and safety regulations in this operating manual may result in death or serious injury!

Do Not Operate Unless:

The personnel have been trained on this type of unit and are deemed competent. All operators should read the operating manual carefully.

1. Avoid hazardous situations.

Know and understand the safety regulations before going on to the next section.

2. Always perform a pre-operation inspection on the lift.

3. Inspect the working area thoroughly before using the lift.

4. Always perform the function test as per the operating manual prior to use.

5. Only use the lift as per the operating instructions. Any deviations are not acceptable. In case, you must always contact the owner of the equipment.

Fundamentals

The working area inspection helps the operator to determine if the working area is suitable for safe lift operation. The inspection should be performed by the operator prior to moving the lift to the working area.

It is the operator's responsibility to read and know the section on working area hazards and to avoid them while moving, setting up or operating the lift.

Ensure the unit is working on solid ground and the loadings applied by the unit will not cause damage or create additional floor loading.

Avoid sources of danger!

Do not operate the lift if you cannot guarantee a safe operation due to one or more of the following sources of danger:

- Inclines, holes or swells on the work surface or debris
- Unstable subsurfaces at the working area
- Insufficient subsurface foundation at the working area
- Subsurfaces with holes, obstructions etc.
- Overhead obstructions such as:
- Beams, electric cables and ropes/wires
- High voltage cables
- Unsuitable wind and weather conditions
- All other possible unsafe surfaces and conditions



Read, understand and obey:

- a) the manufacturer's instructions and safety instructions.
- b) the operating manuals and safety instructions for the lift.
- c) the inscriptions, labels and warning signs on the lift.
- d) the safety instructions and work procedures on the job site.
- e) the relevant legislation in force for the equipment in use.

Function Tests



Non compliance with the instructions and safety regulations in this operating manual may result in death or serious injury!

Do Not Operate Unless:

The personnel have been trained on this type of unit and are deemed competent. All operators should read the operating manual carefully.

1. Avoid hazardous situations.

Know and understand the safety regulations before going on to the next section.

2. Always perform a pre-operation inspection on the lift.

3. Inspect the working area thoroughly before using the lift.

4. Always perform the function test as per the operating manual prior to use.

5. Only use the lift as per the operating instructions. Any deviations are not acceptable. In case, you must always contact the owner of the equipment.

Fundamentals

The function tests are designed to identify malfunctions before the lift goes into service.

The operator must follow the step-by-step instructions and test all lift functions.

A malfunctioning lift must not be operated under any circumstances.

If any malfunctions are discovered the lift must be removed from service and appropriately tagged. Further use of the lift is prohibited.

Repairs to the lift may only be undertaken by a qualified service technician in compliance with the manufacturer's specifications.

When repair work has been successfully completed the operator must perform another pre-operation inspection and repeat the function tests. Only then may the lift be operated.



Read, understand and obey:

- a) the manufacturer's instructions and safety instructions.
- b) the operating manuals and safety instructions for the lift.
- c) the inscriptions, labels and warning signs on the lift.
- d) the safety instructions and work procedures on the job site.
- e) the relevant legislation in force for the equipment in use.

Function Tests /Std Models

Manual Cable Winches | Locking Mechanisms

Manual Winches

1. Disengage the mast element transport safety hook and raise the loading carriage to half of the maximum height of the mast system.
2. Install a loading accessory (e.g.lifting fork).
(See chapter: Installation)
3. Raise the mast by winding the crank handle on the winch clockwise (to the right).

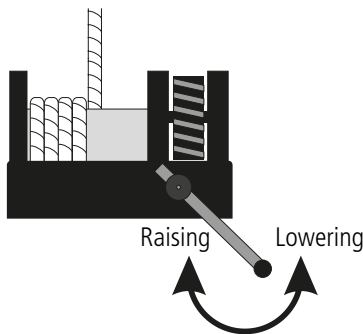

>> The winch should turn evenly without lagging or jamming.

>> An even and adjacent unwinding of the cable on the winch drum should occur. (see figure 1)

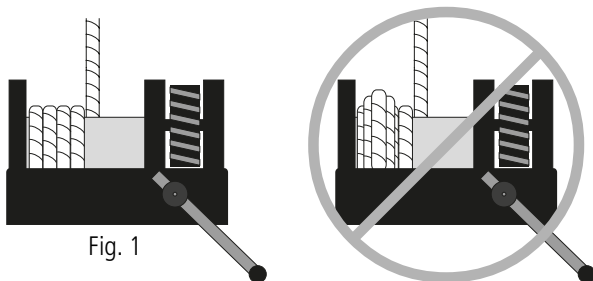

Fig. 1

Stop when the mast element is completely extended.
When winding stops the winch locks automatically.

- >> The winch must be locked firmly.
- >> The crank handle must not move independently.
- >> The mast must not sink independently.

Mast System and Consecutive Extension

Different models have different extension heights. The extension height depends on the number of mast elements. A model with more mast elements will achieve a greater lifting height (see section Technical Data).

RAISING:

1. Disengage the mast element transport safety hook and wind the loading carriage to the height of the winch.
2. Install a loading accessory (e.g.lifting fork).
(See chapter: Installation)
3. Raise the mast by winding the crank handle on the winch clockwise (to the right).

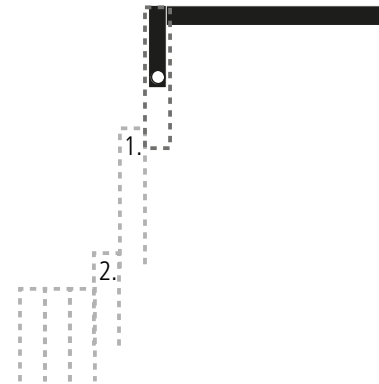

>> When the loading carriage is wound to its full extension, the first mast element should follow easily and without blockage.

>> When the first mast element is wound to its full extension, the second mast element should follow easily and without blockage.

>> Further winding should ensure that successive mast elements reach their full extension easily and without blockage.

LOWERING:

4. Lower the mast by winding the crank handle on the winch anti-clockwise (to the left).

>> The successive mast elements must retract completely without snagging or blocking and in the reverse order when lowering.

>> Cable tension must remain constant during raising and lowering.

Function Tests AC and DC Models

Electric Cable Winches

Electric Winches

RAISING:

- Disengage the mast element transport safety hook and raise the loading carriage to half of the maximum height of the mast system by using the remote control unit.
- Install a loading accessory (e.g. lifting fork). (See chapter: Installation)
- Raise the mast by turning the rotary switch on the remote control unit to **RAISING** (arrow up). The winch drive will remain activated as long as the switch is held in place.

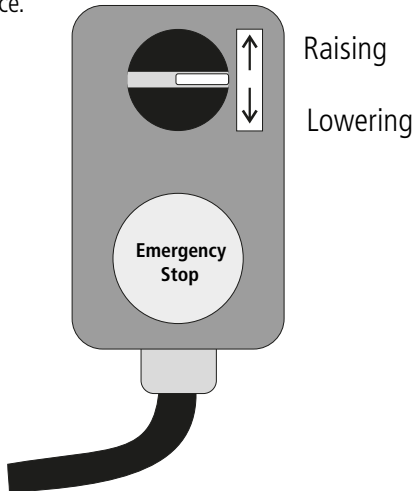

- >> The winch should turn evenly without lagging or jamming.
- >> An even and adjacent unwinding of the cable on the winch drum should occur. (see figure 1)

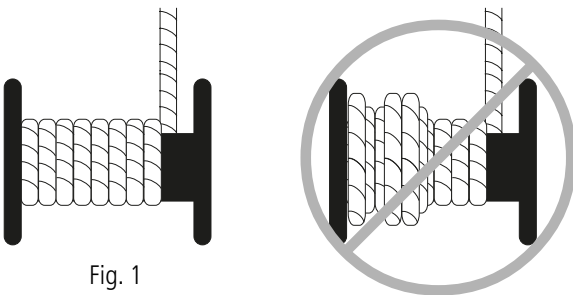

Fig. 1

Winch Deactivation

The winch stops automatically when the rotary switch is released (Raising/Lowering).

- >> The winch must stop and remain still.
- >> The mast must not sink independently.
- >> Cable tension must remain constant.

Mast System and Consecutive Extension

Different models have different extension heights. The extension height depends on the number of mast elements. A model with more mast elements will achieve a greater lifting height (see section Technical Data).

RAISING:

- Disengage the mast element transport safety hook and turn the rotary switch on the remote control unit in the direction **LOWERING** (arrow down) or **RAISING** (arrow up) as required to move the loading carriage to the height of the winch.
- Install a loading accessory (e.g. lifting fork). (See chapter: Installation)
- Raise the mast by turning the rotary switch on the remote control unit to **RAISING** (arrow up). The winch drive will remain activated as long as the switch is held in place.

>> **When the loading carriage is fully extended, the first mast element should follow easily and without blockage.**

When the first mast element is fully extended, the second mast element should follow easily and without blockage.

Further raising should ensure that successive mast elements reach their full extension easily and without blockage.

LOWERING:

- Lower the mast by turning the rotary switch on the remote control unit to **LOWERING** (arrow down). The winch drive will remain activated as long as the switch is held in place.

>> **The successive mast elements must retract completely without snagging or blocking and in the reverse order when lowering.**

>> **Cable tension must remain constant.**

Operating Instructions



Do Not Operate Unless:

- The personnel have been trained on this type of unit and are deemed competent. All operators should read the operating manual carefully.

1. Avoid hazardous situations.

Know and understand the safety regulations before going on to the next section.

2. Always perform a pre-operation inspection on the lift.

3. Inspect the working area thoroughly before using the lift.

4. Always perform the function test as per the operating manual prior to use.

5. Only use the lift as per the operating instructions. Any deviations are not acceptable. In case, you must always contact the owner of the equipment.

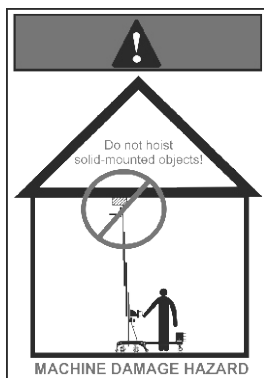

MACHINE DAMAGE HAZARD

Do not hoist solid-mounted objects!

Do not wedge the lift with immovable objects, which could result in tipping-over.

Fundamentals

Using the lift for anything other than lifting loads is unsafe.

If more than one operator is expected to use a lift at different times during the same work shift, each individual operator is expected to know and follow all of the safety regulations and instructions in the operating manual.

This means that every new lift operator should know and adhere to the safety regulations and instructions described in the previous chapters before operating the lift.

Therefore, the following tasks must be undertaken by each operator before initial operation:

- Read and understand this operating manual
- Pre-operation inspection
- Function tests
- Working area inspection
- Operating instructions
- Compliance with and application of the information in the load capacity chart

Installation GML/Std

Converting the lift from transport position to operating position.

Set up the lift on firm and level ground only.

Ensure that all caster safety brakes on the chassis are engaged during set up.

GML/Std
Transport position:

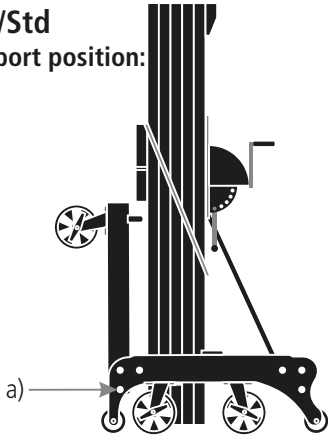

Lowering the
outrigger:

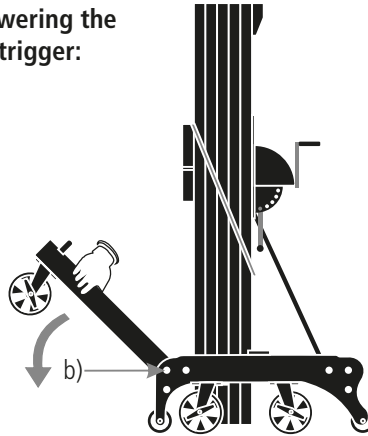

Securing the
outrigger:

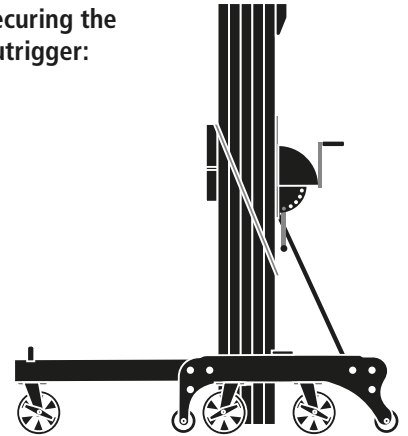

1. Maintain a firm grip on the outrigger before you proceed with step 2! The outrigger may fall unexpectedly. Always lower the outriggers individually and one side after the other.
2. Remove the socket pin (a) completely from the chassis.

3. Lower the outrigger carefully until the wheels are in full contact with the floor surface.

Please note:
The front fixing pin on the chassis (b) works as an axle when lowering the outrigger. The outrigger cannot be removed.

4. Place the socket pin in the upper rear slot (b) in order to re-connect the outrigger to the chassis.
5. Repeat steps 1 to 4 for the outrigger on the opposite side.

**Installing the
handlebar:**

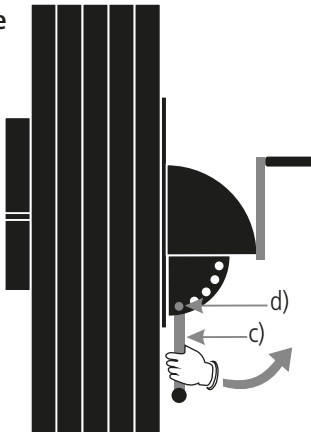

**Securing the
handlebar:**

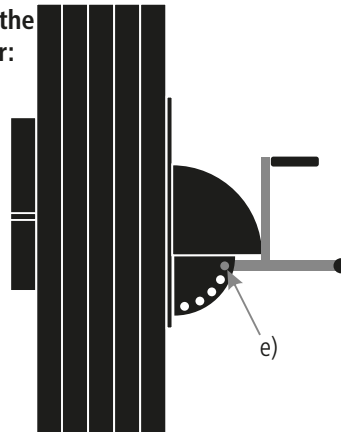

6. To bring the handles of the small handlebar (c) into a horizontal position, remove the locking pin (d) from the handlebar and raise the handlebar upwards to the required position.

7. When the handlebar is in a horizontal position, insert the locking pin into the upper slot (e) of the adjusting plate to resecure the handlebar.

Please note:
There are a range of slots on the adjusting plate which offer further settings for the handlebar to suit the height of the operator.

**Steering the
lift:**

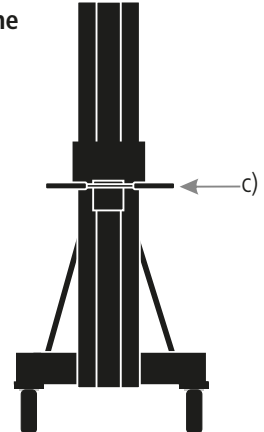

8. Position yourself behind the mast and between the outriggers and use the handlebar (c) to steer the lift.

WARNING:

1. Never operate the lift with only one outrigger!
2. Both outriggers must be pointing in the same direction! Otherwise the lift must not be operated!
3. Never move the lift with a raised load! Only allow for minor position changes.
4. Avoid sudden movements.

Installation GML/Std

Conversion from transport position GML/K.

Set up the lift on firm and level ground only.

Ensure that all caster safety brakes on the chassis are engaged during set up.

GML/K
Transport position

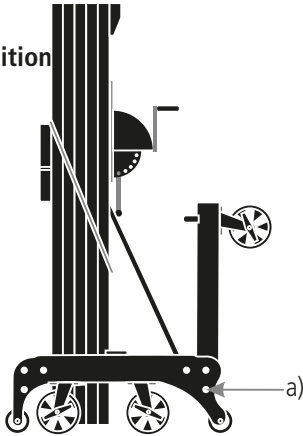

1. Maintain a firm grip on the outrigger before you proceed with step 2! The outrigger may fall unexpectedly. Always lower the outriggers individually and one side after the other.
2. Remove the socket pin (a) completely from the chassis.

Lowering the
outrigger:

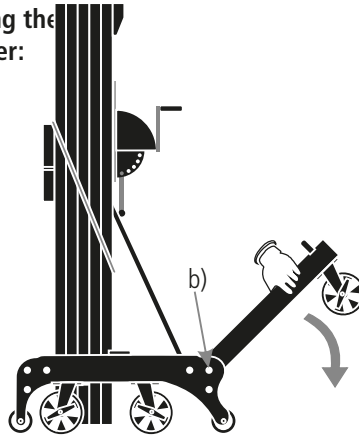

3. Lower the outrigger carefully until the wheels are in full contact with the floor surface.
4. Loosen the nut and bolt (b) that attach the outrigger to the chassis. Remove the bolt completely. Keep the bolt and nut within easy reach.

Dismantling the
outrigger:

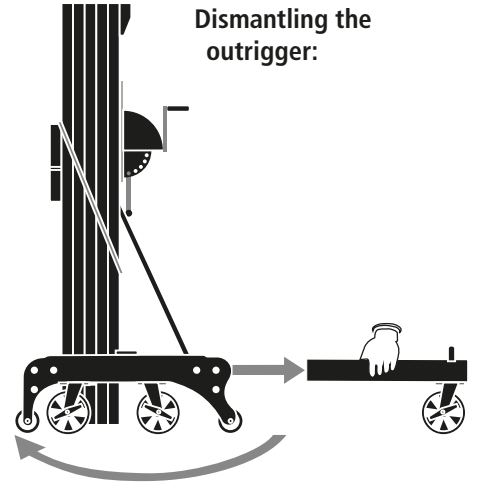

5. Hold the outrigger firmly and remove it completely from the chassis.

**Frontal installation of
the outrigger:**

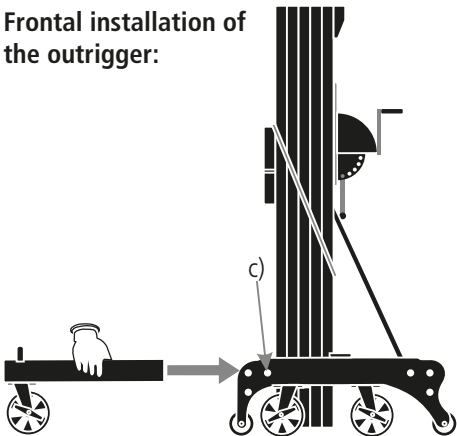

6. Position the outrigger at the front of the chassis. Secure the outrigger by inserting the bolt in slot (b) in the chassis and lock it in place by tightening the nut.

**Securing the
outrigger:**

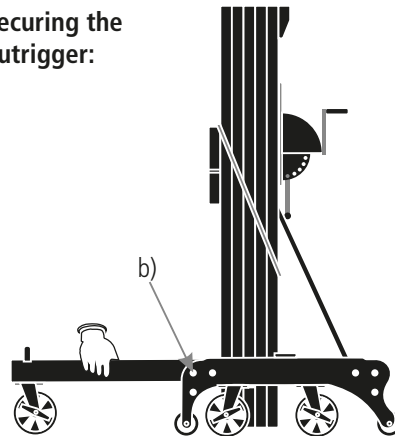

7. Insert the safety splint in the upper slot (c) beside the bolt (b).
8. Repeat steps 1 - 7 for the second outrigger.

WARNING:

1. Never operate the lift with only one outrigger!
2. Both outriggers must be pointing in the same direction! Otherwise the lift must not be operated!
3. Never move the lift with a raised load! Only allow for minor position changes.
4. Avoid sudden movements.

Installation GML/Std

Conversion from operating position GML/K.

Set up and adjust the lift on firm and level ground only.
Ensure that all caster safety brakes on the chassis are engaged during set up and adjustment.

GML/K
Operating
position:

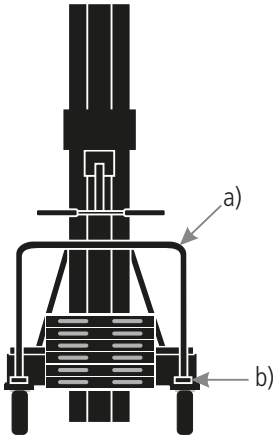

1. To remove the steering arm (a) disengage the lock on the spring pins (b) on both sides of the handlebar and remove the pins.

Dismantling the
steering arm:

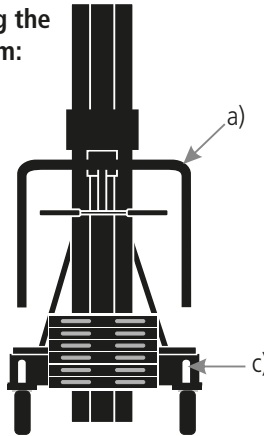

2. Carefully remove the steering arm (a) from the outrigger bolts (c).

Dismantling the
weight box:

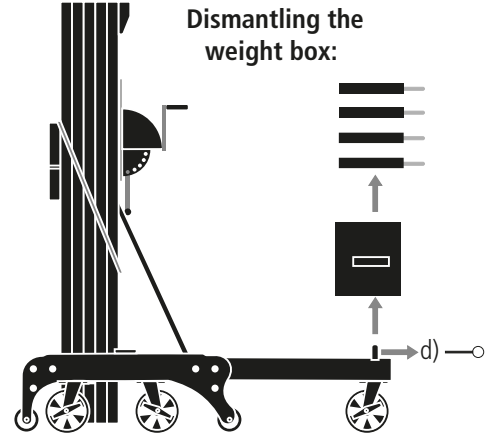

3. Remove all of the counterweights from the weight box.
4. Disengage the safety ring on the locking bolts on both sides of the weight box (d) and remove the bolts.
5. Remove the box from the outrigger.

Dismantling the
outrigger:

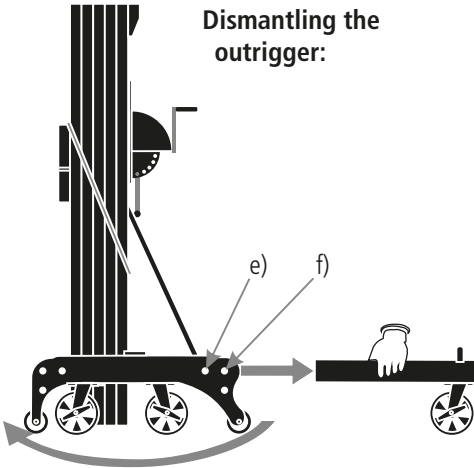

6. Unscrew and remove the socket pin (e) completely from the chassis.
7. Loosen the bolt and nut (f) that attach the outrigger to the chassis. Remove the bolt completely. Keep the nut and bolt within easy reach.
8. Hold the outrigger firmly and remove it completely from the chassis.

Frontal installation of
the outrigger:

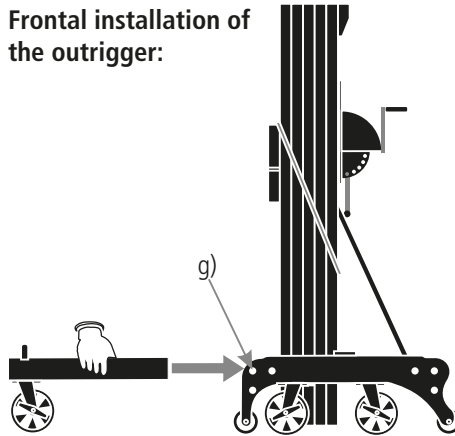

9. Position the outrigger at the front of the chassis. Secure the outrigger by inserting the bolt in slot (g) in the chassis and lock it in place by tightening the nut.

Securing the
outrigger:

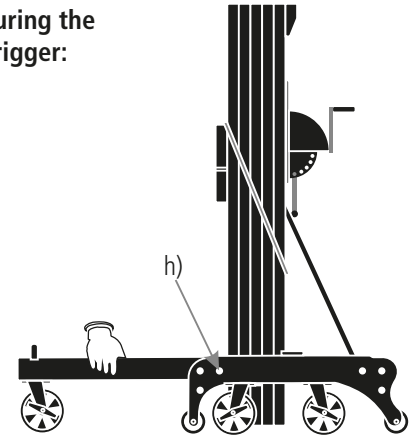

10. Insert the socket pin in the upper slot (h) beside the bolt (g).
11. Repeat steps 6 - 10 for the second outrigger.



WARNING:

1. Never operate the lift with only one outrigger!
2. Both outriggers must be pointing in the same direction! Otherwise the lift must not be operated!
3. Never move the lift with a raised load! Only allow for minor position changes.
4. Avoid sudden movements.

Installation GML/K

Converting the lift from transport position to operating position.

Set up the lift on firm and level ground only.

Ensure that all caster safety brakes on the chassis are engaged during set up.

GML/K Transport position:

Components:

- 1) 1x Weight box
- 2) 2x Safety bolt boxes
- 3) 12 x 35 lbs Weights
- 4) 1x Steering arm
- 5) Steering arm spring bolts

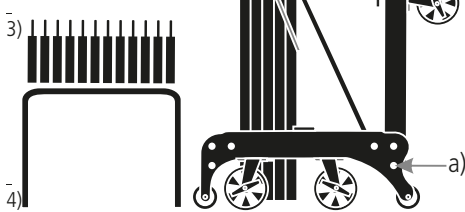

1. Maintain a firm grip on the outrigger before you proceed with step 2! The outrigger may fall unexpectedly. Always lower the outriggers individually and one side after the other.

2. Remove the socket pin (a) completely from the chassis.

Lowering the outrigger:

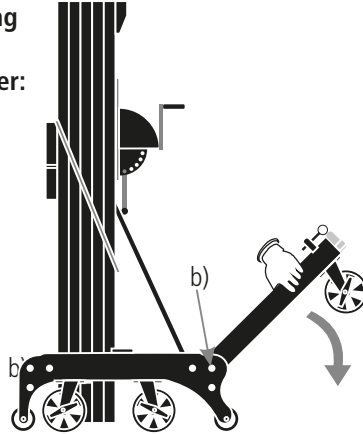

3. Lower the outrigger carefully until the wheels are in full contact with the floor surface.

Please note:

The front fixing pin on the chassis (b) works as an axle when lowering the outrigger. The outrigger cannot be removed.

Securing the outrigger:

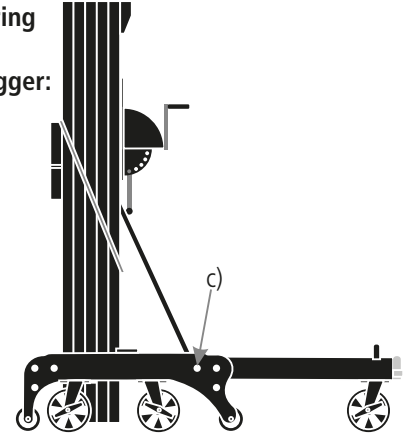

4. Place the socket pin in the upper rear slot (c) in order to re-connect the outrigger to the chassis.

5. Repeat steps 1 to 4 for the outrigger on the opposite side.

Installing the weight box:

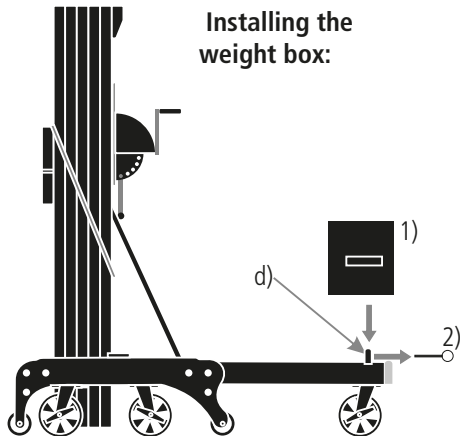

6. Remove both socket pins (2) from the receptor pins for the weight box (d) by releasing the safety ring.
7. Position the weight box (1) on the receptors on both outriggers (d).
8. Secure the weight box with the socket pins (2) on both sides and reactivate the safety ring on the locking bolts.

Filling the weight box:

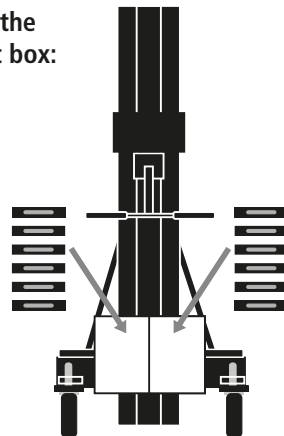

9. Completely fill the weight box with the counterweights. Stack the counterweights flatly, one on top of the other, 6 x 35 lbs on each side of the weight box.

WARNING:

Only use lift specific counterweights!

Installing the steering arm:

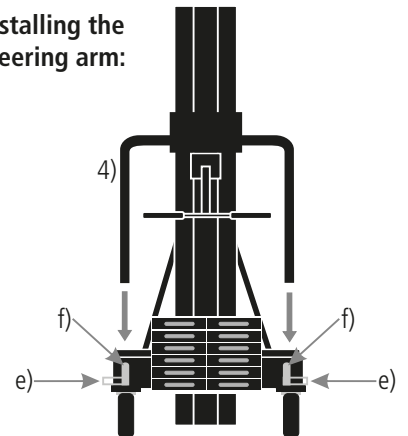

10. Disengage the spring bolts (e) on the socket pins (f) at the rear end of both outriggers and completely remove the spring bolts. Keep both spring bolts within easy reach.

11. Place the steering arm (4) on both socket pins (f) and resecure it with the previously removed spring bolts (e).



WARNING:

1. NEVER operate the GML/K unless the weight box is completely filled!
2. Never operate the lift with only one outrigger!
3. Both outriggers must be pointing in the same direction! Otherwise the lift must not be operated!
4. Never move the lift with a raised load! Only allow for minor position changes.
5. Avoid sudden movements.

Installation GML/K

Conversion from transport position GML/Std.

Set up the lift on firm and level ground only.
Ensure that all caster safety brakes on the chassis are engaged during set up.

GML/Std Transport position:

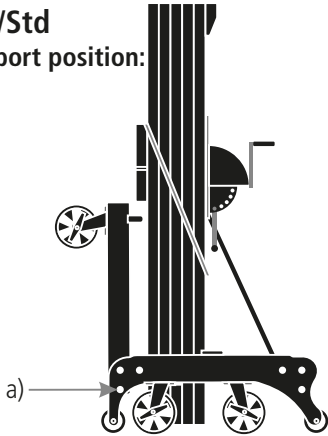

1. Maintain a firm grip on the outrigger before you proceed with step 2! The outrigger may fall unexpectedly. Always lower the outriggers individually and one side after the other.
2. Remove the socket pin (a) completely from the chassis.

Lowering the outrigger:

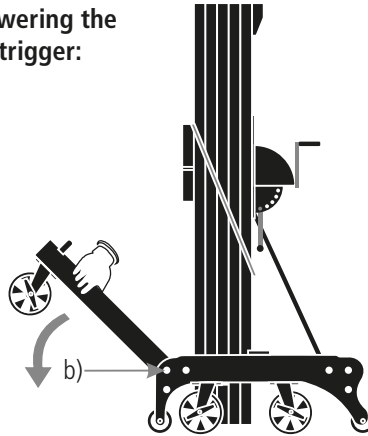

3. Lower the outrigger carefully until the wheels are in full contact with the floor surface.
4. Loosen the bolt and nut (b) that attach the outrigger to the chassis. Remove the bolt completely. Keep the nut and bolt within easy reach.

Securing the outrigger:

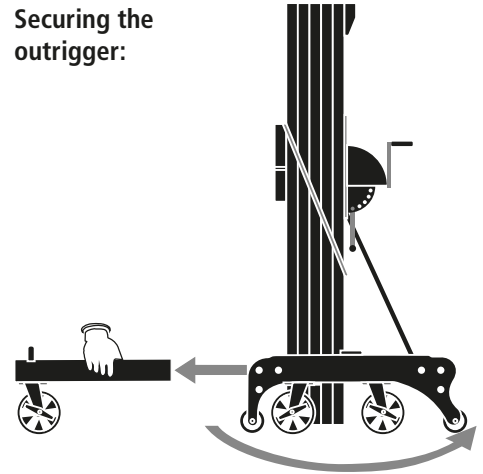

5. Hold the outrigger firmly and remove it completely from the chassis.

Rear installation of the outrigger:

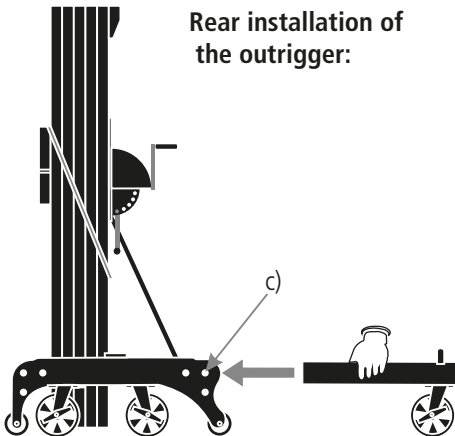

6. Position the outrigger at the rear of the chassis. Secure the outrigger by inserting the bolt in slot (c) in the chassis and lock it in place by tightening the nut.

Securing the outrigger:

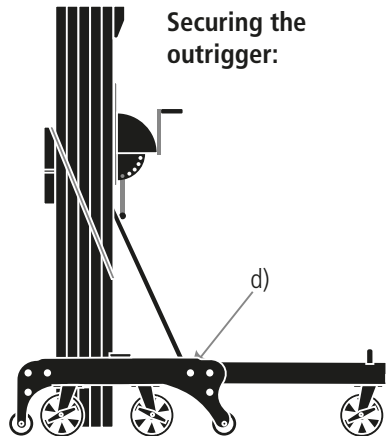

7. Insert the safety splint in the upper slot (d) beside the bolt (c).
8. Repeat steps 1 - 7 for the second outrigger.



WARNING:

1. NEVER operate the GML/K unless the weight box is completely filled!
2. Never operate the lift with only one outrigger!
3. Both outriggers must be pointing in the same direction! Otherwise the lift must not be operated!
4. Never move the lift with a raised load! Only allow for minor position changes.
5. Avoid sudden movements.

Installation GML/K

Conversion from transport position GML/Std.

Set up the lift on firm and level ground only.

Ensure that all caster safety brakes on the chassis are engaged during set up.

Installing the weight box:

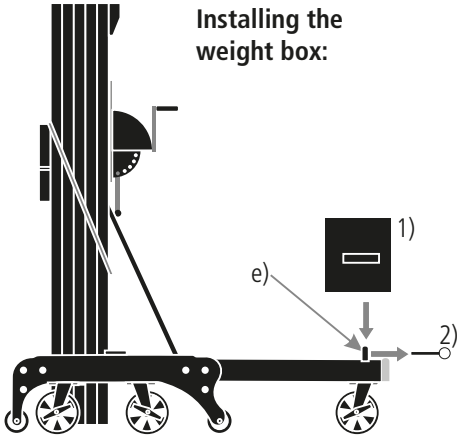

9. Remove both socket pins (2) from the fitting pins for the weight box (e).
10. Position the weight box (1) on the receptors on both outriggers (e).
11. Secure the weight box with the socket pins (2) on both sides and engage the safety ring on the locking bolts.

Filling the weight box:

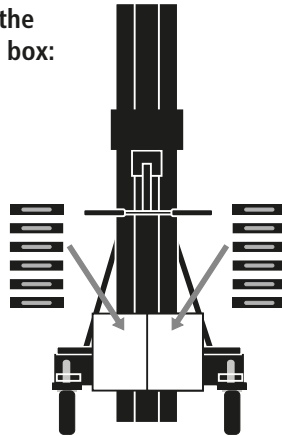

12. Completely fill the weight box with the counterweights. Stack the counterweights flatly, one on top of the other, 6 x 35 lbs on each side of the weight box.

WARNING:
Only use lift specific counterweights!

Installing the steering arm:

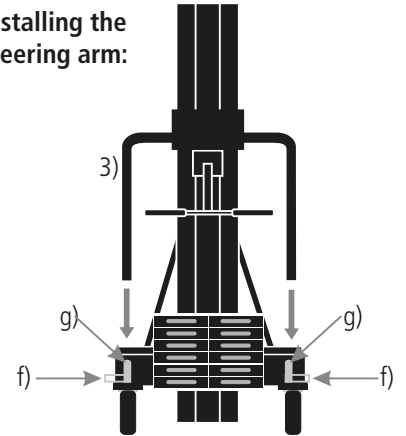

13. Disengage the spring bolts (f) on the socket pins (g) at the rear end of both outriggers and completely remove the spring bolts. Keep both spring bolts within easy reach.
14. Place the steering arm (3) on both socket pins (g) and resecure it with the previously removed spring bolts (f).

! WARNING:

Never move the lift with a raised load!
Only allow for minor position changes.
Avoid sudden movements.

! WARNING:

1. NEVER operate the GML/K unless the weight box is completely filled!
2. Never operate the lift with only one outrigger!
3. Both outriggers must be pointing in the same direction! Otherwise the lift must not be operated!
4. Never move the lift with a raised load! Only allow for minor position changes.
5. Avoid sudden movements.

Installation GML/K

Conversion from operating position GML/Std.

Set up the lift on firm and level ground only.

Ensure that all caster safety brakes on the chassis are engaged during set up.

GML/Std
Operating position:

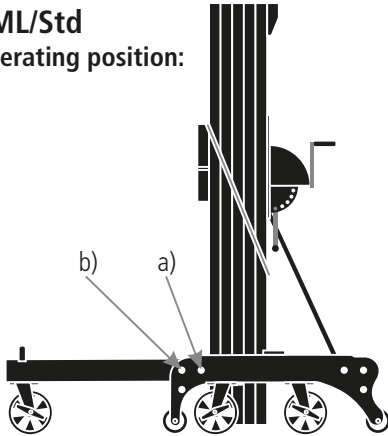

1. Remove the socket pin (a) completely from the chassis.
2. Loosen the nut and bolt (b) that attach the outrigger to the chassis. Remove the bolt completely. Keep the nut and bolt within easy reach.

Securing the outrigger:

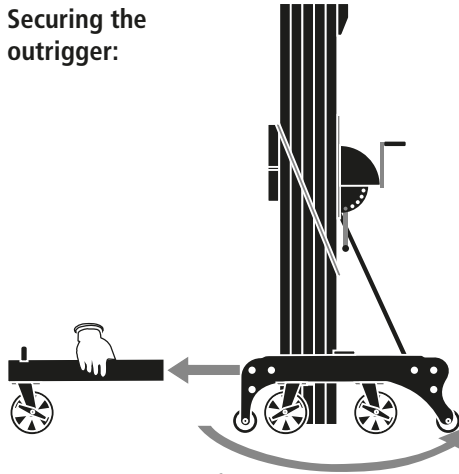

3. Hold the outrigger firmly and remove it completely from the chassis.

Rear installation of the outrigger:

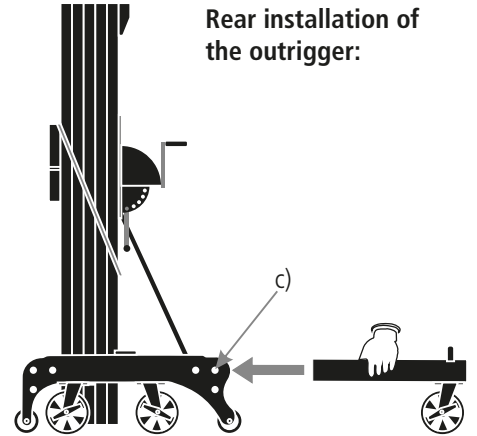

4. Position the outrigger at the rear of the chassis. Secure the outrigger by inserting the bolt in slot (c) in the chassis and lock it in place by tightening the nut.

Securing the outrigger:

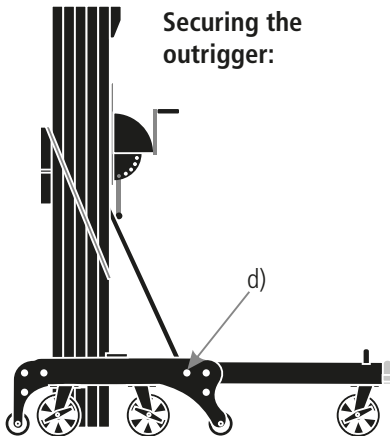

5. Place the socket pin in the upper slot (c) beside the bolt (d).
6. Repeat steps 1 - 5 for the second outrigger.

Installing the weight box:

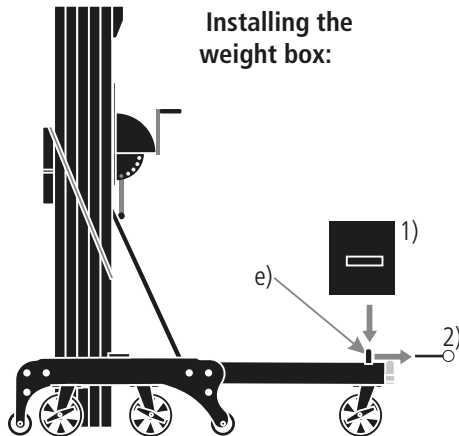

7. Position the weight box (1) on the receptors on both outriggers (e).
8. Secure the weight box with the socket pins (2) on both sides and engage the safety ring on the locking bolts.

Filling the weight box:

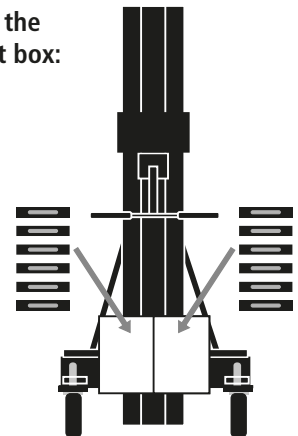

9. Completely fill the weight box with the counterweights. Stack the counterweights flatly, one on top of the other, 6 x 35 lbs on each side of the weight box.

WARNING:

Only use lift specific counterweights!

! WARNING:

1. NEVER operate the GML/K unless the weight box is completely filled!
2. Never operate the lift with only one outrigger!
3. Both outriggers must be pointing in the same direction! Otherwise the lift must not be operated!
4. Never move the lift with a raised load! Only allow for minor position changes.
5. Avoid sudden movements.

Installation GML/K

Conversion from operating position GML/Std.
Aligning the swivel casters for maximum loading capacity

Set up the lift on firm and level ground only.
Ensure that all caster safety brakes on the chassis are engaged during set up.

Installing the steering arm:

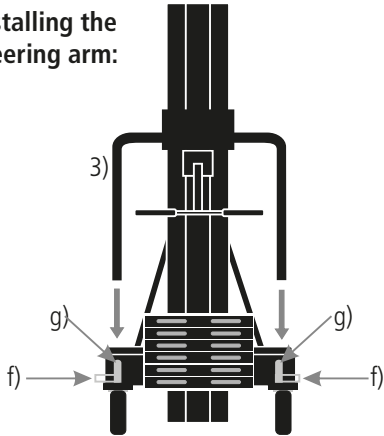

10. Disengage the spring bolts (f) on the socket pins (g) at the rear end of both outriggers and completely remove the spring bolts. Keep both spring bolts within easy reach.
11. Place the steering arm (3) on both socket pins (g) and resecure it with the previously removed spring bolts (f).

Aligning swivel casters for maximum loading capacity

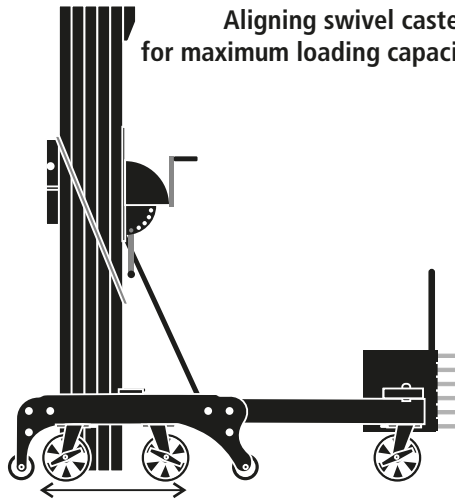

In order to position the lift so that the maximum pay load may be raised, the large swivel casters on both sides of the chassis have to be so aligned that the maximum distance between them is achieved, as depicted in the figure below.

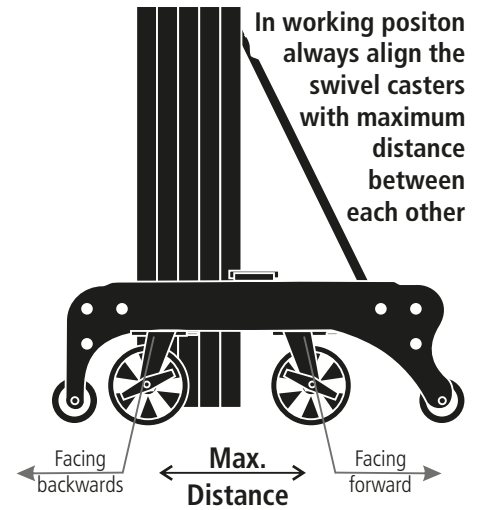

Aligning casters for maximum load capacity:

1. Front casters are
 - facing FORWARD
 - and locked.
2. Rear casters are
 - facing BACKWARDS
 - and locked.

! WARNING:

Never move the lift with a raised load!
Only allow for minor position changes.
Avoid sudden movements.

! CAUTION:

The loading capacity varies subject to model, design and installed loading accessory.

Never exceed the values listed in the loading capacity chart and the load centre chart when raising a load.

! WARNING:

1. NEVER operate the GML/K unless the weight box is completely filled!
2. Never operate the lift with only one outrigger!
3. Both outriggers must be pointing in the same direction! Otherwise the lift must not be operated!
4. Never move the lift with a raised load! Only allow for minor position changes.
5. Avoid sudden movements.

Installation GML/K DC

Outrigger and Battery Cart.

Set up the lift on firm and level ground only.
Ensure that all caster safety brakes on the chassis are engaged during set up.

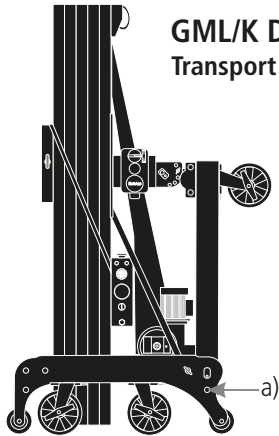

GML/K DC
Transport position:

1. Maintain a firm grip on the outrigger before you proceed with step 2! The outrigger may fall unexpectedly. Always lower the outriggers individually and one side after the other.
2. Remove the socket pin (a) completely from the chassis.

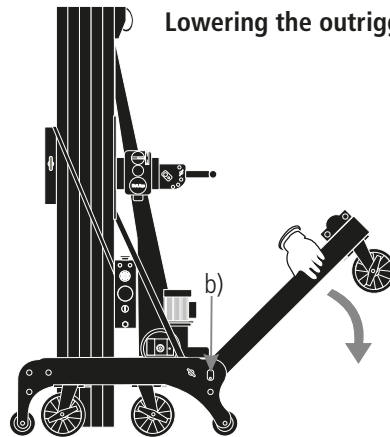

Lowering the outrigger:

3. Lower the outrigger carefully until the wheels are in full contact with the floor surface.

Please note:
 The front fixing pin on the chassis (b) works as an axle when lowering the outrigger. The outrigger cannot be removed.

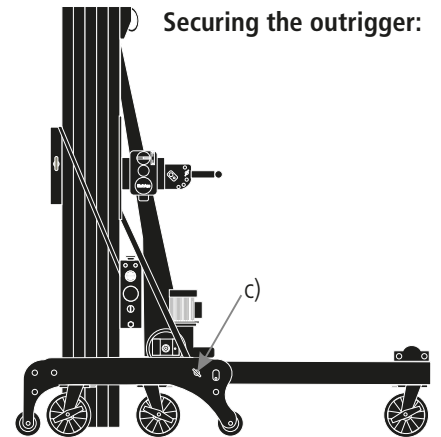

Securing the outrigger:

4. Place the socket pin in the upper rear slot (c) in order to re-connect outrigger and chassis.
5. Repeat steps 1 to 4 for the outrigger on the opposite side.

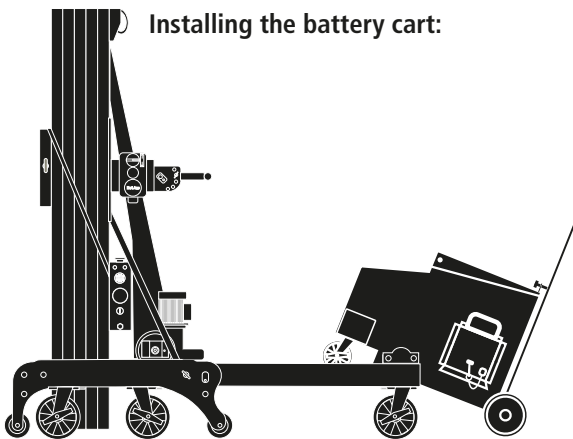

Installing the battery cart:

6. Tilt the battery cart slightly and push it on the back end onto the outrigger - until it is locked on both sides into the slip-on.

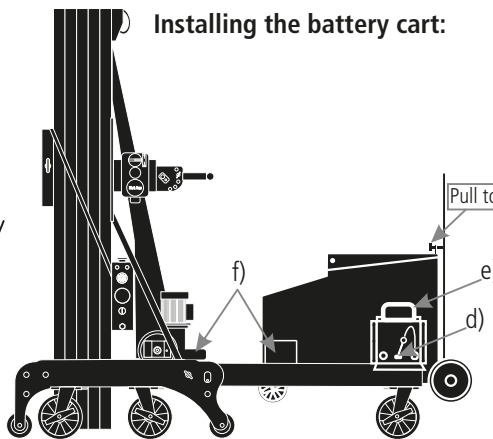

Installing the battery cart:

7. To fix the battery cart, insert the locking bolt through the slip-on eye (d) on both sides of the battery cart.
8. In case if not fulfilled: fill up 3 counterweights (e) in the boxes on the left and right side of the Battery Cart.
- 9) Connect power supplies between winch and battery cart (f).

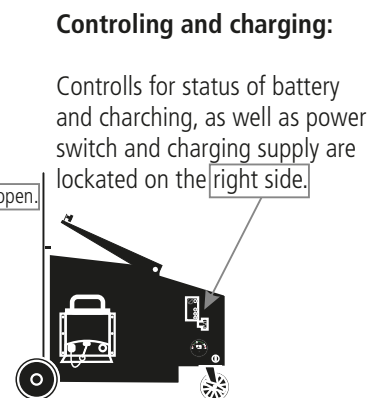

Controlling and charging:

Controls for status of battery and charging, as well as power switch and charging supply are locked on the right side.

For access to batteries and charging unit you have to pull the locking bolt as shown above.



WARNING:

1. NEVER operate the GML/K unless the weight box is completely filled!
2. Never operate the lift with only one outrigger!
3. Both outriggers must be pointing in the same direction! Otherwise the lift must not be operated!
4. Never move the lift with a raised load! Only allow for minor position changes.
5. Avoid sudden movements.

Installation Lateral outrigger at /20 + /25 models.

Lateral outriggers are as standard on all /20 and /25 models.
Available as additional accessory for /10 and /15 models.

Set up the lift on firm and level ground only.

Ensure that all caster safety brakes on the chassis are engaged during set up.

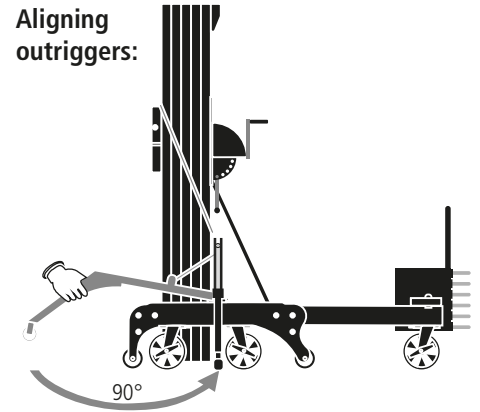
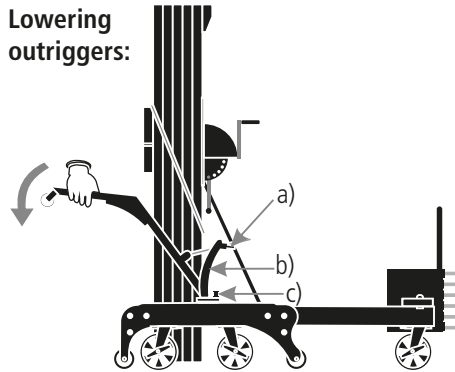
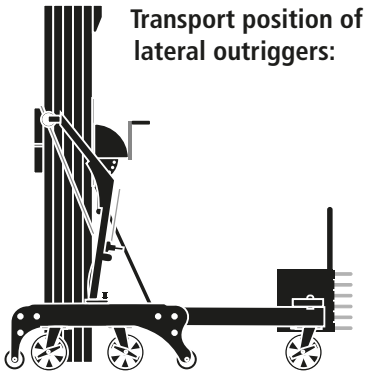

The models GML 800+ /20 and /25 reach lifting heights of more than 5 metres. In order to increase the stability of the lift, the lateral outriggers must always be installed.

The models GML 800+ /10 and /15 reach a maximum lifting height of 5 metres. The installation of lateral outriggers for the models /10 and /15 is therefore optional. (Model type see nameplate)

1. Hold the outrigger firmly. Press down the brake plate (a) on the support strut (b). Lower the outrigger towards the front until the caster is approximately 5 - 10 cm from the work surface.

2. Pull the locking pin (c) on the adjustment plate upwards and maintain a solid grip on it in order to rotate the outrigger to the desired position.

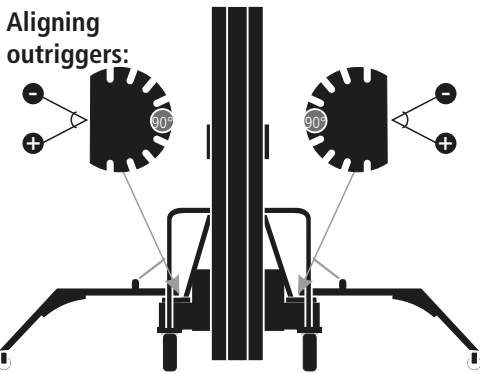

Setting Example

90° lateral outrigger alignment.

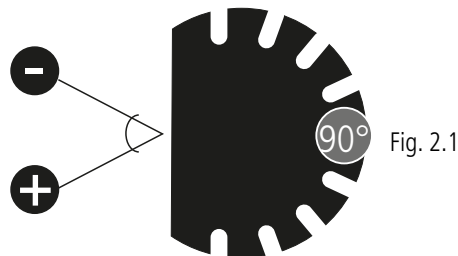

3. To secure the outrigger, release the locking pin (Fig. 2.1). Ensure that the locking pin slips correctly into the adjustment notch (Fig. 2.2). Shake the outrigger lightly to verify that the locking pin is correctly locked in place.

4. Repeat steps 1 - 3 for the second outrigger.

1. NEVER operate the GML/K unless the weight box is completely filled!
2. Never operate models GML 800+ /20 and /25 (Lifting height > 196 in) without lateral outriggers!
3. Both lateral outriggers must have the same alignment on each side.
4. The locking pins must be correctly locked in the notch on the adjustment plate.
5. Never move the lift with a raised load! Only allow for minor position changes.
6. Avoid sudden movements.

Disengaging/Re-engaging the Mast Safety Hook

Removing/fitting the safety bar

Always ensure that the lift is in the correct operating position and that the safety brakes on the wheels and swivel casters are engaged before attempting to dismantle or refit the mast element transport safety hook.

Lowering the carriage:

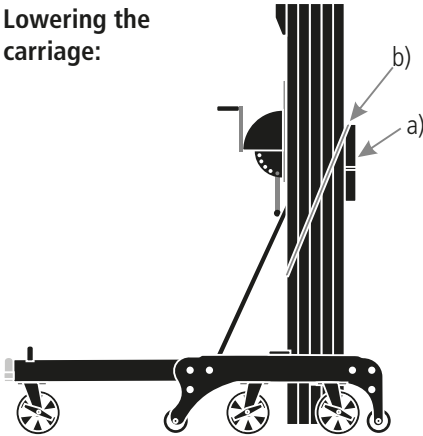

1. Lower the carriage (a) slightly to loosen the safety bar (b) on the carriage. This is done by winding the crank handle on the winch a little to the right.

Removing the mast element transport safety hook:

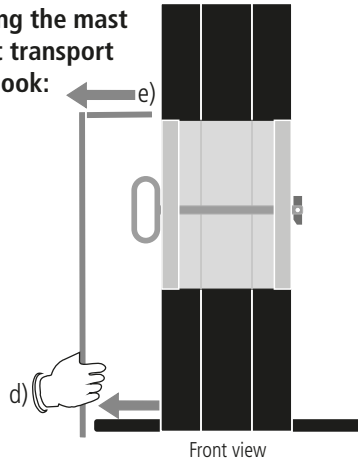

2. Grip the safety bar at the BOTTOM (d) and pull it towards you until it is able to pass by the mast system (e).

Repositioning the mast element transport safety hook:



3. Maintain a firm grip on the bottom of the safety bar and move the TOP of the safety bar to the first mast section (in the direction of the winch).

4. Release the grip on the BOTTOM of the safety bar and slide the TOP of the safety bar slowly into the first mast section.

Fitting the mast element transport safety hook

In order to reset the mast element transport safety hook, repeat the above steps in reverse order:

1. Grip on the bottom and pull.
2. Slip the hook past the mast system.
3. Refit the safety bar at the front, above the carriage.
4. Wind the winch slightly to the left. (Raise the carriage)



WARNING:

The greater the distance between the load and the carriage, the lower the allowed loading capacity! See load centre chart.

Standard Loading Device Installation

Fitting/removing a lifting fork or crane outrigger to/from the carriage

Set up the lift on firm and level ground only.

Ensure that all caster safety brakes on the chassis are engaged during set up.

Aligning the carriage:

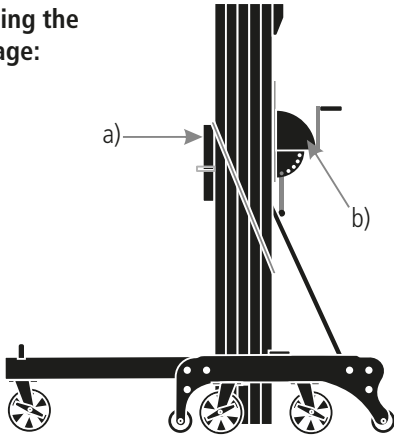

1. In order to install the lifting fork easily to the carriage, bring the carriage (a) to a suitable height by winding the winch (b).

Unlocking the safety bolt:

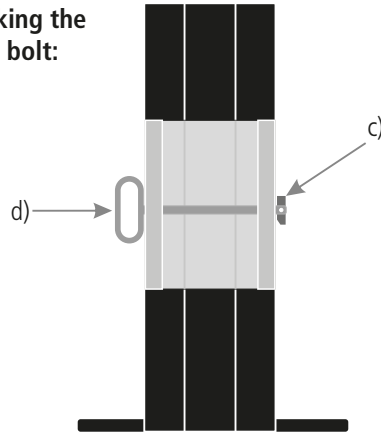

2. Release the splint (c) to enable removal of the safety bolt (d).

Securing and releasing the safety bolt:

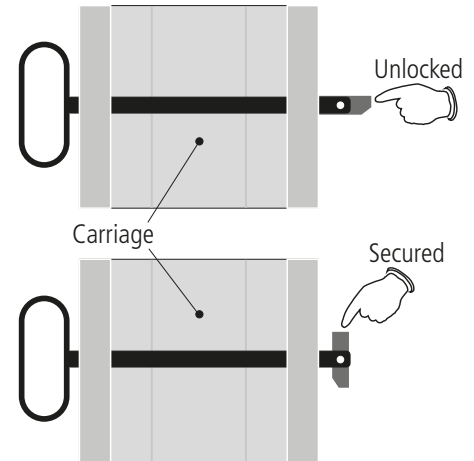

Installing the lifting fork from UNDERNEATH: (Low loading height)

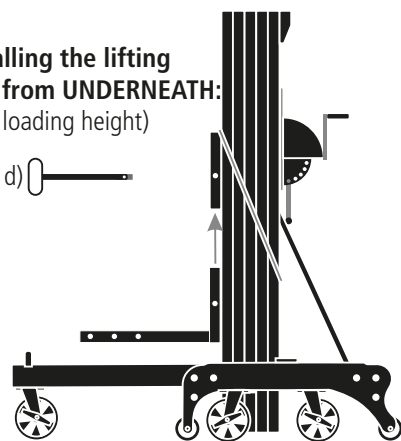

3. Remove the disengaged safety bolt (d) completely from the carriage.
4. Install the lifting fork on the carriage from **underneath**. **Align the slots on the lifting fork with those on the carriage.**
5. When both slots are at the same height, insert the safety bolt through the carriage and the loading accessory.
6. To secure the bolt, vertically install the splint (= "secured" position).

Installing the lifting fork from ABOVE: (More lifting height)

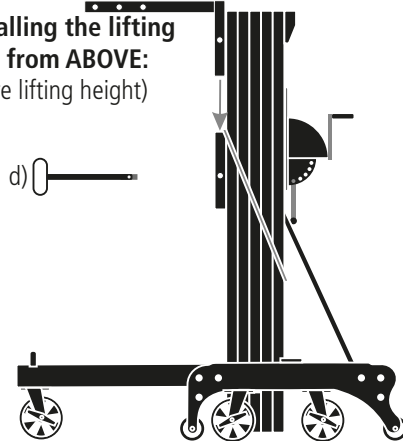

3. Remove the disengaged safety bolt (d) completely from the carriage.
4. Install the lifting fork on the carriage from **above**. **Align the slots on the lifting fork with those on the carriage.**
5. When both slots are at the same height, insert the safety bolt through the carriage and the loading accessory.
6. To secure the bolt, vertically install the splint (= "secured" position).

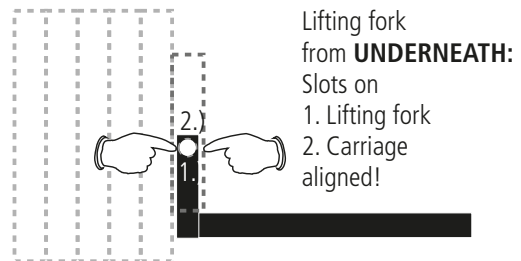

Lifting fork from **UNDERNEATH**:
Slots on
1. Lifting fork
2. Carriage aligned!

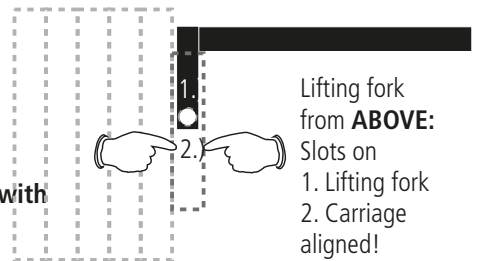

Lifting fork from **ABOVE**:
Slots on
1. Lifting fork
2. Carriage aligned!

! WARNING:

Ensure that the forks of the lift are not bent or damaged prior to use!

Load Positioning

Positioning and securing the load.

**Ensure that the loads are centered and secured to the loading accessory before lifting.
The safety brakes must be engaged before lifting.**

Position the load correctly on the loading accessory being used. Ensure that the load is adequately secured! Incorrectly positioned and/or incorrectly secured loads may lead to accidents that result in death or serious injury!

Load Positioning Instructions

1. Determine the weight of the load and identify the location of its load centre.
2. Position the load
 - a) with its load centre as close as possible to the mast system/carriage
 - b) in the centre of the loading accessory
3. Measure the distance between the mast system/carriage and the load centre of the load that is positioned on the loading accessory.
4. Always refer to the load centre chart to ensure that the lift is capable of lifting the load in its current position.
5. Ensure that the load is adequately secured.
6. Always align the large swivel casters on the chassis so that the maximum distance possible between them is achieved when working with the maximum allowed load.

Load Centre Instructions

A load centre is defined as the balancing point (centre of gravity) of a load. The load centre must always be positioned within the load centre zone as prescribed in the load centre chart!

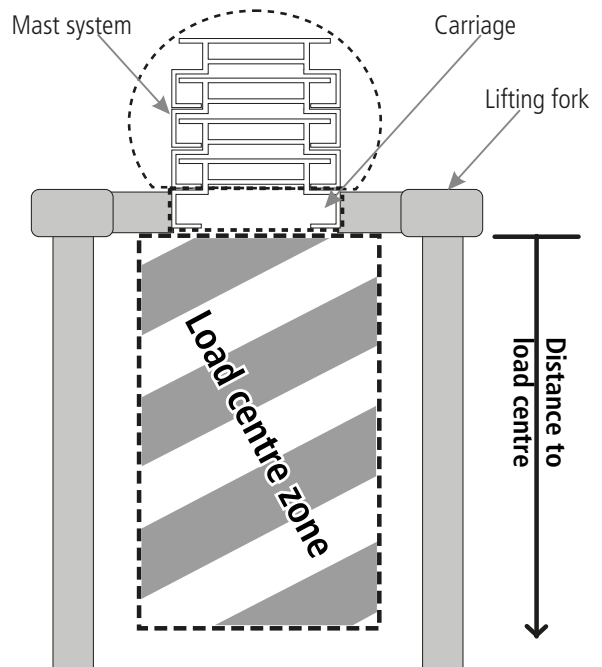

- ! On both sides of the chassis**
1. The front caster has to face FORWARD.
 2. The rear caster has to face BACKWARDS.

- ! Ensure that the load being lifted does not exceed the maximum load carrying capacity relative to the current load centre.**

Always obey the specifications on the load carrying capacity chart. Do not ever exceed the prescribed specifications - under any circumstances!

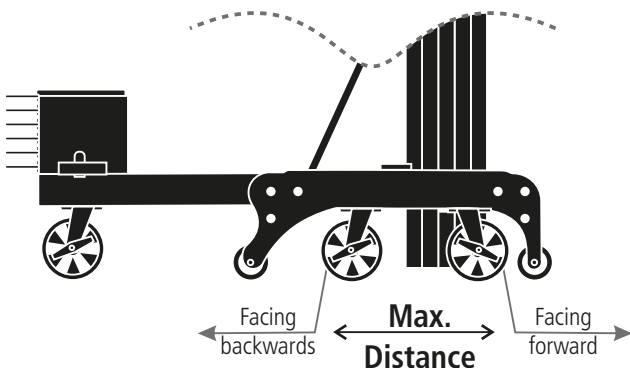

! WARNING:

Positioning the load centre of a load outside of the load centre zone may lead to accidents that result in death or serious injury!

Load Centre

Positioning a load in relation to the load centre.

Ensure that the loads are centered and secured at the loading accessory before lifting.
The safety brakes must be engaged before lifting.

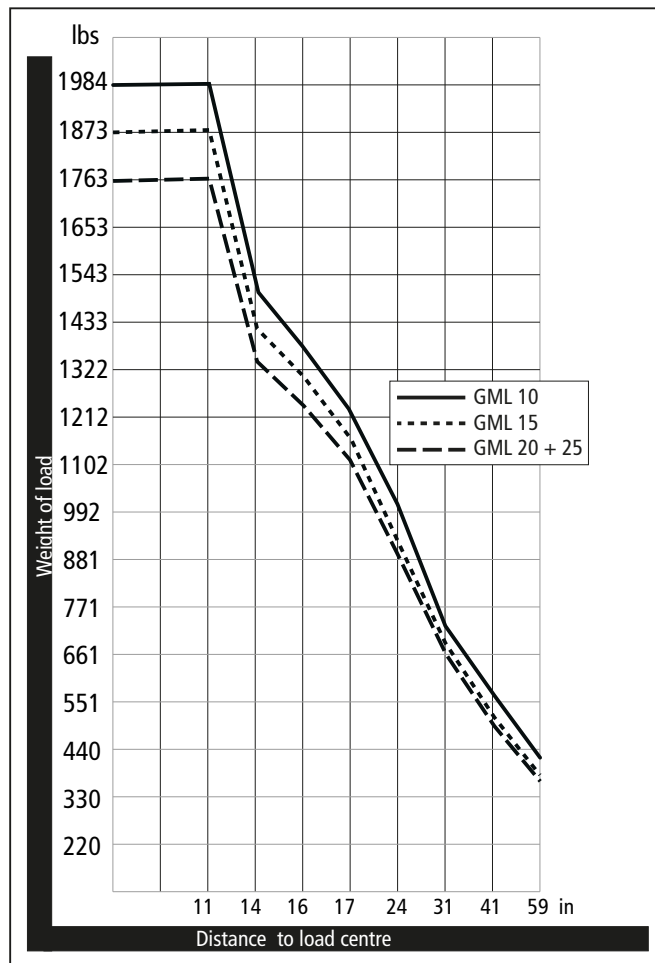
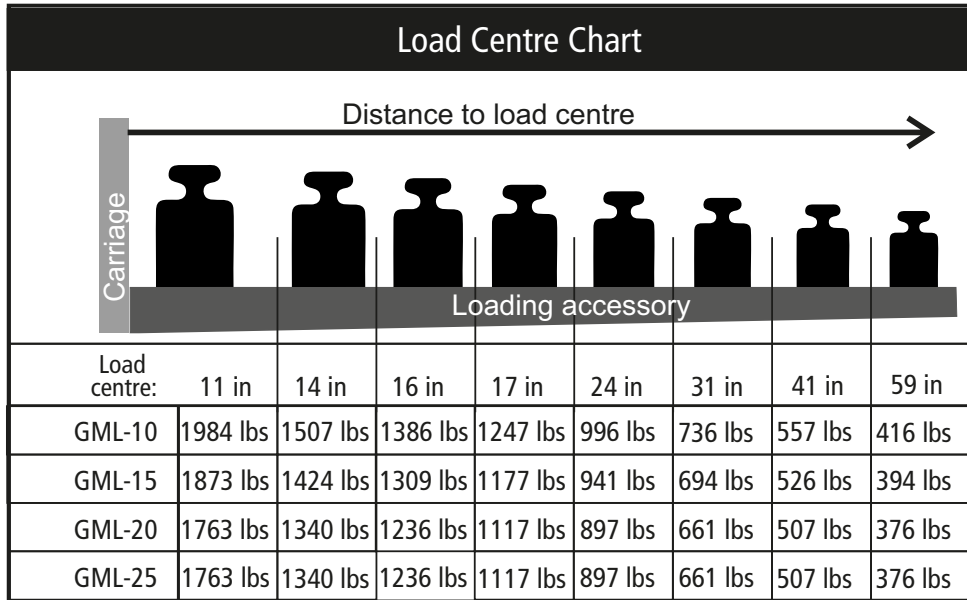

WARNING

Positioning the load centre of a load outside of the load centre zone may lead to accidents that result in death or serious injury!

Wienold Glass and Material Lift GML 800+

Raising and Lowering with a manual Winch.

Operating the worm gear winch on M-Models.

Operate the lift on firm and level ground only. Perform a pre-operation function test and convert the lift to the operating position as described in the section headed "Installation".

Ensure that all safety brakes on the swivel casters are engaged when working with a load.

Moving the loaded lift

An extended lift may only be moved when not loaded. Moving a raised load has to be restricted to positioning for loading and unloading.

Moving a lift with a raised load should only occur as a last resort. In such a situation the following safety regulations must be obeyed:

1. **Lower the load as far as possible before moving the lift.**
2. **Make sure the area is flat and free from obstruction.**
3. **Ensure the load is centered on the loading accessory.**
4. **Ensure the load is secured to the loading accessory.**
5. **Avoid sudden stops and starts.**
6. **Keep personnel at a safe distance from the lift and the load.**

After Each Use

Follow the set-up procedure in reverse order to prepare the lift for storage or to convert it into its transport position.

Select a safe storage location with a firm level, weather protected surface and clear of obstructions and traffic.

Raising and lowering loads

1. Place the load in the centre of the loading accessory. Also refer to section "load capacity charts"!
2. Secure the load on the loading accessory.
3. **Raise** the load by turning the crank handle on the winch clockwise (**to the right**). Maintain a firm grip on the crank handle.
4. **Lower** the load by turning the crank handle on the winch anti-clockwise (**to the left**). Maintain a firm grip on the crank handle.

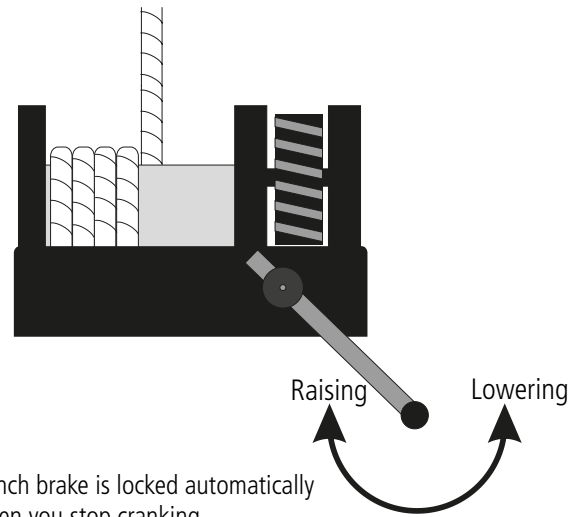

During raising and lowering make sure that the cable tension remains constant and that the cable winds evenly around the cable drum.

Raising and Lowering with an AC-Electric Winch.

Operating the electric winch on AC-Models (230/110V).

Operate the lift on firm and level ground only. Perform a PRE-OPERATION function test and convert the lift to the operating position as described in the section headed "Installation".

Ensure that all safety brakes on the swivel casters are engaged when working with a load.

The 230/110V Electric Winch

1. Centre the load on the loading accessory and secure it against toppling.

2. Use the cable extension in order to connect the plug of the control system to a 230/110 V socket.

! WARNING!
Use the cable drum or better still unwind the cable completely from the drum in order to avoid the possibility of a short circuit caused by overheating!

3. To **switch on** the winch insert the key into the key switch 8) and turn it TO THE LEFT. When the green signal lamp 4) is on, the winch is ready to be operated.

4. **Raise** the load by turning the rotary switch on the cable control 1) to the upwards switch setting FOR RAISING 2). As soon as the rotary switch is released the winch will automatically stop.

5. **Lower** the load by turning the rotary switch on the cable control 1) to the downwards switch setting FOR LOWERING 2). As soon as the rotary switch is released the winch will automatically stop.

6. To **switch off** the winch return the key in the key switch back to a vertical position. The green signal lamp will go off if the current is turned off.

! IMPORTANT!

The lift possesses two automatic limit switches that deactivate the rotary switch of the control system and automatically stops the winch immediately when the loading accessory has either reached its lowest position (when LOWERING) or its highest position (when RAISING).

Emergency release:

If the lift is malfunctioning it is crucial that the electric emergency release is deployed. It automatically lowers the loading accessory and activates the red signal lamp 5). If there is a malfunction the winch and cable control system will not operate due to safety requirements. Call a service technician!

Control System:

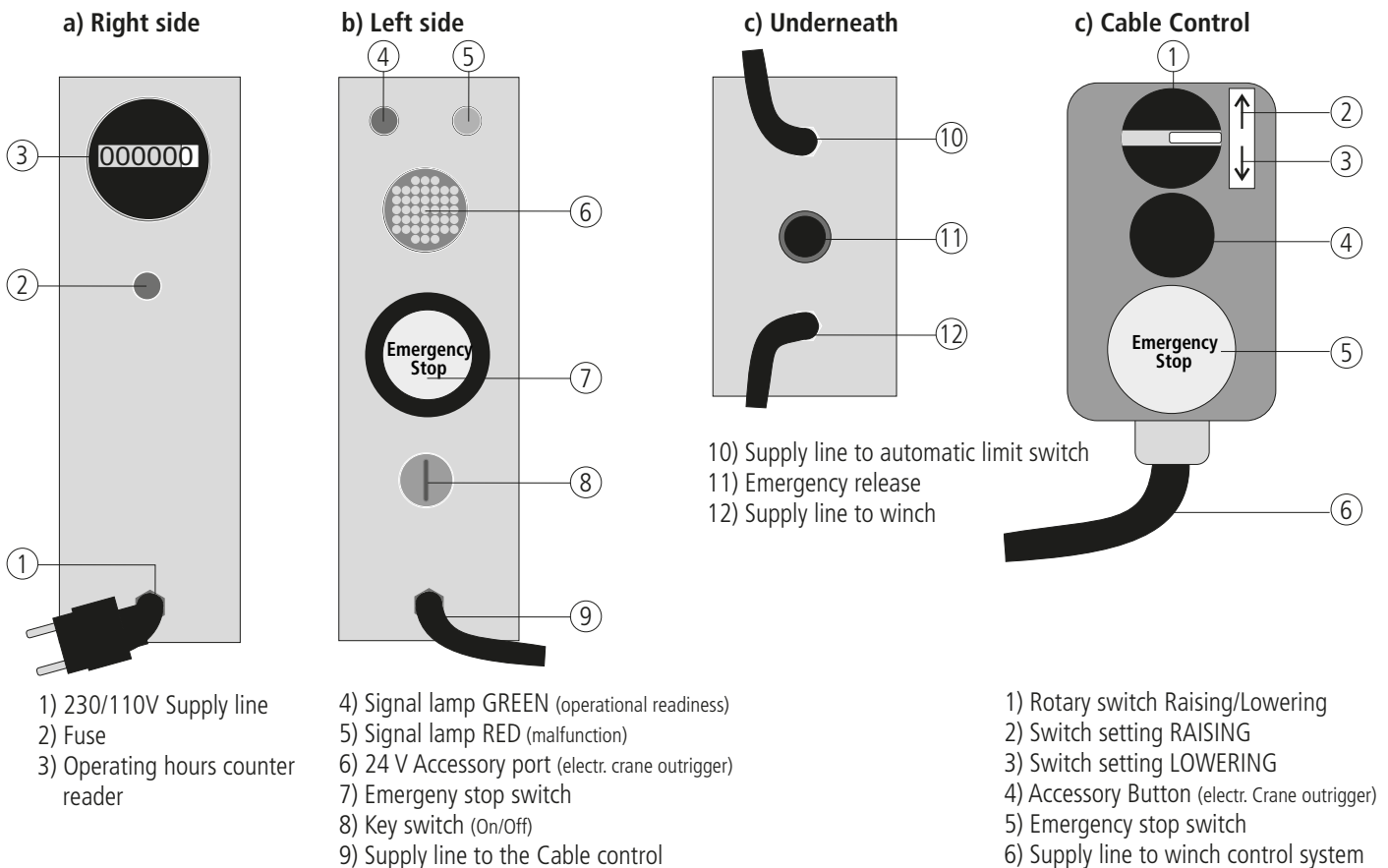

Raising and Lowering with an DC-Electric Winch.

Operating the electric winch on DC-Models (24V).

Operate the lift on firm and level ground only. Perform a PRE-OPERATION function test and convert the lift to the operating position as described in the section headed "Installation".

Ensure that all safety brakes on the swivel casters are engaged when working with a load.

24V PowerPack Electric Winch

- Centre the load on the loading accessory and secure it against toppling.
- Ensure that the battery wagon is converted to its operating position as described in the section heading **INSTALLATION GML /K DC**.
- Connect the plug and the coupling of the battery wagon and winch in order to supply the winch with energy.
- Inspect the status of the battery charge by looking at the voltmeter display (a target of: 23V). If the charging status is less than 23 Volts, charge the batteries prior to the operation of the lift. If the charging current is too low then the mast system will not be able to reach its full extension.
- To **switch on** the winch insert the key into the key switch 8) and turn it TO THE LEFT. When the green signal lamp 4) is on, the winch is ready to be operated.
- Raise** the load by turning the rotary switch on the cable control 1) to the upwards switch setting FOR RAISING 2). As soon as the rotary switch is released the winch will automatically stop.
- Lower** the load by turning the rotary switch on the cable control 1) to the downwards switch setting FOR LOWERING 2). As soon as the rotary switch is released the winch will automatically stop.
- To **switch off** the winch return the key in the key switch back to a vertical position. The green signal lamp will go off if the current is turned off.



IMPORTANT!

The lift possesses two automatic limit switches that deactivate the rotary switch of the control system and automatically stops the winch immediately when the loading accessory has either reached its lowest position (when LOWERING) or its highest position (when RAISING).

Emergency release:

If the lift is malfunctioning it is crucial that the electric emergency release is deployed. It automatically lowers the winch and loading accessory and activates the red signal lamp 5). If there is a malfunction the winch and cable control system will not operate due to safety requirements. Call a service technician!

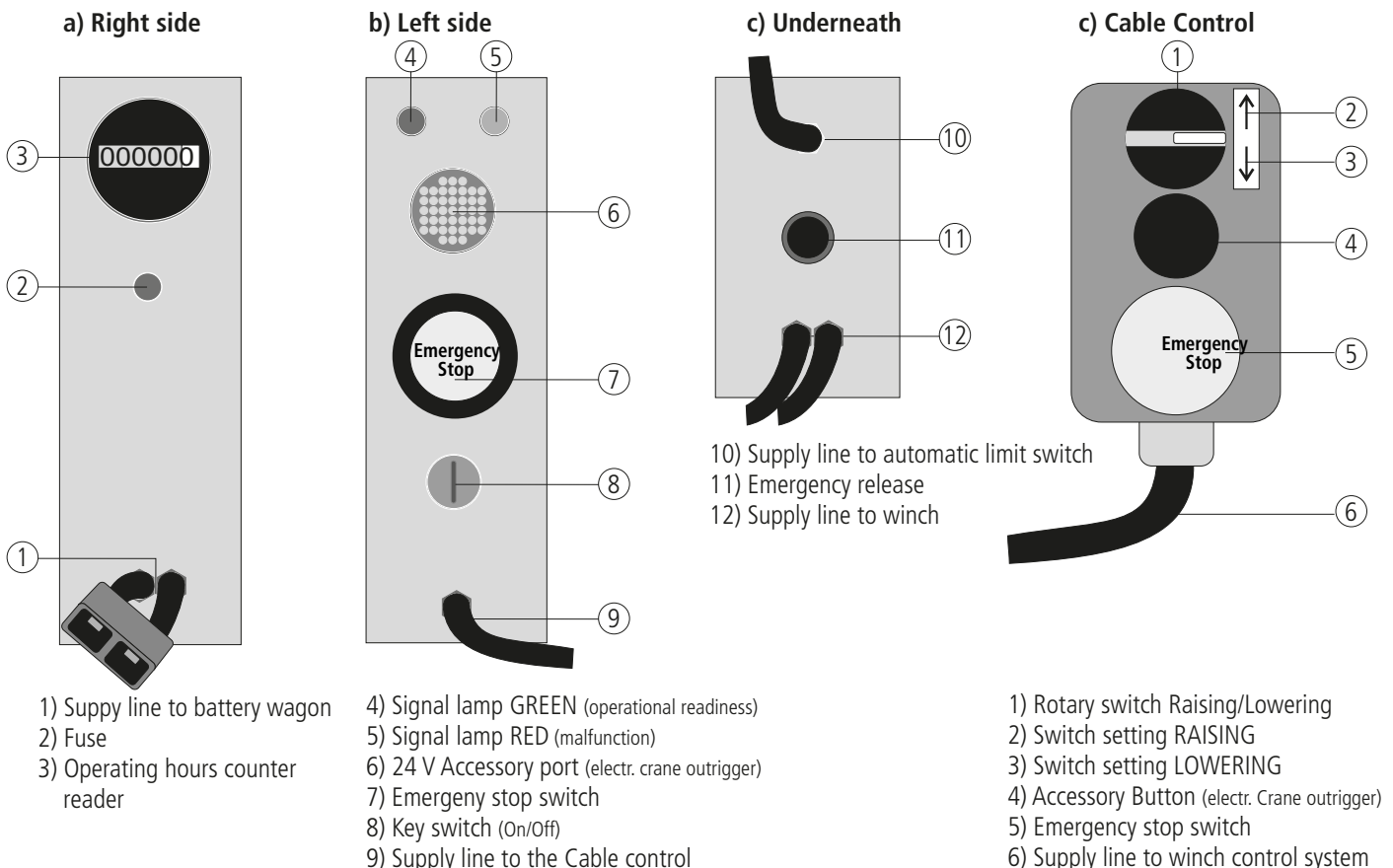

DC-Series Charging Batteries

Battery Cart for charging batteries at 230/110V.

The winch operates only if there is enough capacity on the batteries.

Preferably do not operate/use the lift whilst charging the batteries.

The 230/110 Volt electric cable does not charge the winch – only the batteries!

24V batteries charging

1. To check how far the batteries are charged, the electric control box must be switched on. Insert the key into the key switch and TURN TO LEFT.
2. Then check the display in the voltmeter. If the display shows less than 20 volt charge, the batteries must be charged before using the lift (s. fig. a).
- 3) For charging the batteries the control box must be switched OFF by positioning the key into vertical position. The green light goes off, when the circuit is interrupted.

4. For charging the batteries an extension cable should be used. Connect the cable with the charger of the battery cart (fig. c) and 230/110 volt socket.



WARNING!

In case of using a cable drum, the cable must be fully rolled out to avoid a short cut or overheating. !

After 6-8 hrs the batteries should be fully charged. If the display shows 24-26 volt, the batteries are fully charged (s. fig. b).

- 5) To show the actual state of charge, switch the control box shortly on and off (s. prescription 1.-3).

6. When the batteries are fully charged, disconnect the extension cable from the socket.
7. To avoid voltage loss during storage or transportation, the connector between battery cart and control box should be disconnected.

a) Batteries FLAT:

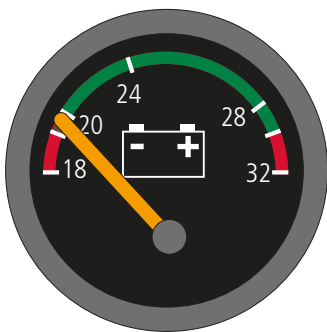

b) Batteries CHARGED:

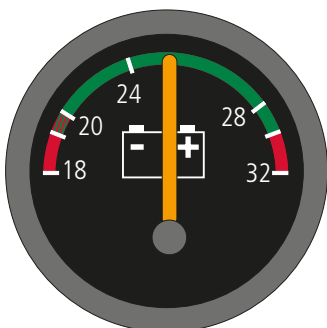

c) Power/Charger - front view:

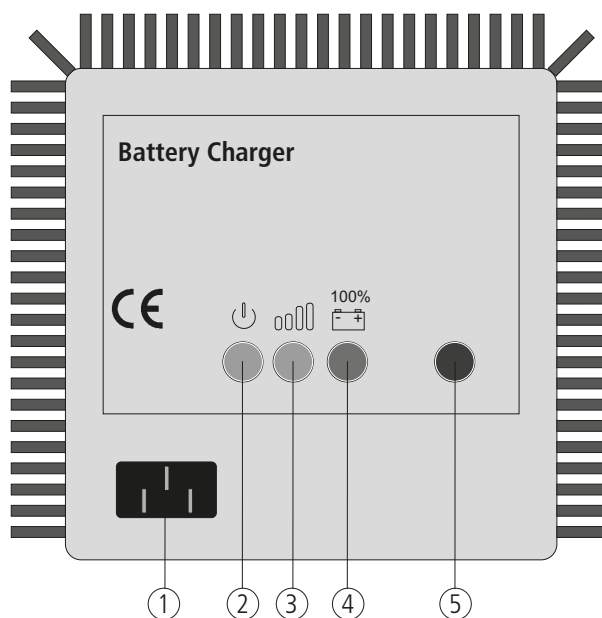

- 1) Power/Charger (230/110V)
- 2) Yellow LED: Power gets supplied to charger
- 3) Yellow LED: Batteries will be charged
- 4) Green LED: Batteries fully charged (100%)
- 5) Red LED: Electrical interference

d) Controlbox right view:

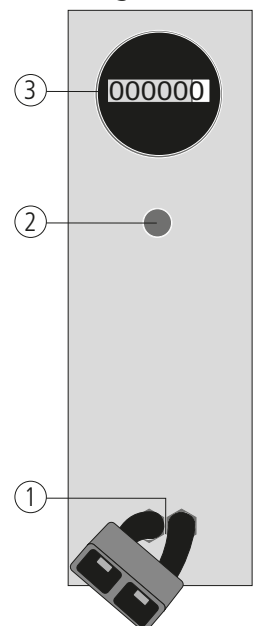

- 1) Connector battery cart / control box (located on the frame of the chassis)
- 2) Fuse
- 3) Operating hour counter

MODEL 27TMX with POD vent

VOLTAGE 12

MATERIAL Polypropylene

DIMENSIONS Inches (mm)

BATTERY Deep-Cycle Flooded/Wet Lead-Acid Battery

COLOR Maroon

WATERING N/A



12V

PRODUCT + PHYSICAL SPECIFICATIONS

BCI Group Size	Type	Voltage	Cell(s)	Terminal Type ⁶	Dimensions ⁶ Inches (mm)			Weight Lbs. (kg)
					Length	Width	Height ^f	
27	27TMX	12	6	7, 8, 9, 16	12.84 (326)	6.60 (168)	9.74 (247)	55 (25)

ELECTRICAL SPECIFICATIONS

Cranking Performance		Capacity ^A Minutes		Capacity ^B Amp-Hours (AH)				Energy (kWh)	Internal Resistance (mΩ)	Short Circuit Current (amps)
C.C.A. ⁹ @0°F(-18°C)	C.A. ⁵ @32°F(0°C)	@ 25 Amps	@ 75 Amps	5-Hr	10-Hr	20-Hr	100-Hr	100-Hr		
—	—	175	45	85	97	105	117	1.40	—	—

CHARGING INSTRUCTIONS

System Voltage	Charger Voltage Settings (at 77°F/25°C)			
	12V	24V	36V	48V
Bulk Charge	14.82	29.64	44.46	59.28
Float Charge	13.50	27.00	40.50	54.00
Equalize Charge	16.20	32.40	48.60	64.80

Do not install or charge batteries in a sealed or non-ventilated compartment. Constant under or overcharging will damage the battery and shorten its life as with any battery.

CHARGING TEMPERATURE COMPENSATION

Add	Subtract
0.005 volt per cell for every 1°C below 25°C 0.0028 volt per cell for every 1°F below 77°F	0.005 volt per cell for every 1°C above 25°C 0.0028 volt per cell for every 1°F above 77°F

OPERATIONAL DATA

Operating Temperature	Self Discharge
-4°F to 113°F (-20°C to +45°C). At temperatures below 32°F (0°C) maintain a state of charge greater than 60%.	5–15% per month depending on storage temperature conditions.

STATE OF CHARGE MEASURE OF OPEN-CIRCUIT VOLTAGE





Percentage Charge	Specific Gravity	Cell	12 Volt
100	1.277	2.122	12.73
90	1.258	2.103	12.62
80	1.238	2.083	12.50
70	1.217	2.062	12.37
60	1.195	2.040	12.24
50	1.172	2.017	12.10
40	1.148	1.993	11.96
30	1.124	1.969	11.81
20	1.098	1.943	11.66
10	1.073	1.918	11.51



Designed in compliance with applicable BCI, DIN, BS and IEC standards.
Tested in compliance to BCI and IEC standards.



TERMINAL CONFIGURATIONS ⁶

7	UT	Universal Terminal
	Terminal Height Inches (mm) 1.10 (28) Torque Values in-lb (Nm) 95 – 105 (11 – 12) Bolt 5/16"	
9	WNT	Wingnut Terminal
	Terminal Height Inches (mm) 1.50 (38) Torque Values in-lb (Nm) 95 – 105 (11 – 12) Bolt 5/16"	
8	AP	Automotive Post Terminal
	Terminal Height Inches (mm) 0.83 (21) Torque Values in-lb (Nm) 50 – 70 (6 – 8)	
16	SLT	Small L-Terminal
	Terminal Height Inches (mm) 1.31 (33) Torque Values in-lb (Nm) 95 – 105 (11 – 12) Bolt 5/16"	

BATTERY DIMENSIONS (shown with WNT)

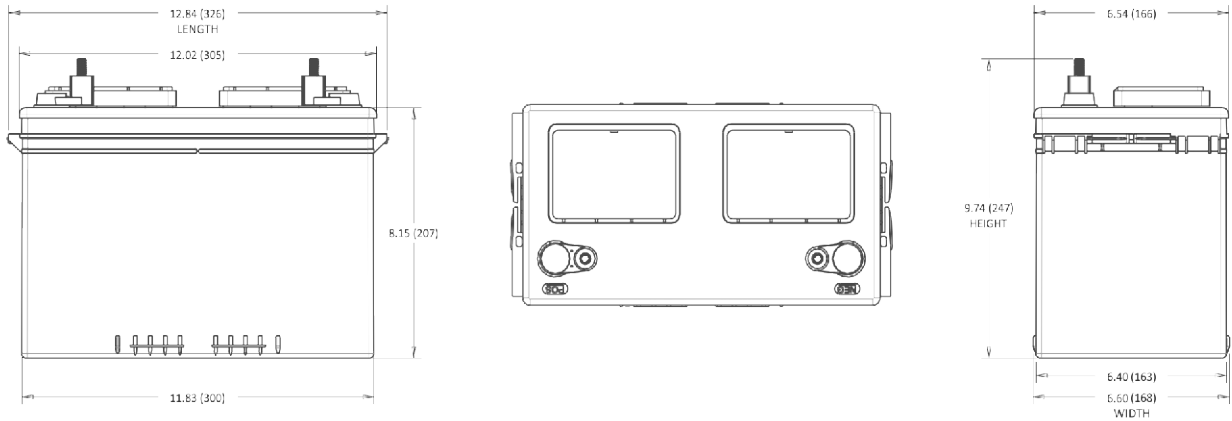

TROJAN 27TMX PERFORMANCE

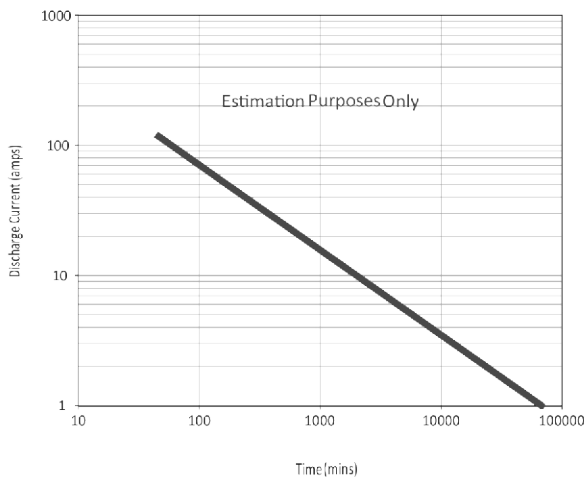

PERCENT CAPACITY VS. TEMPERATURE

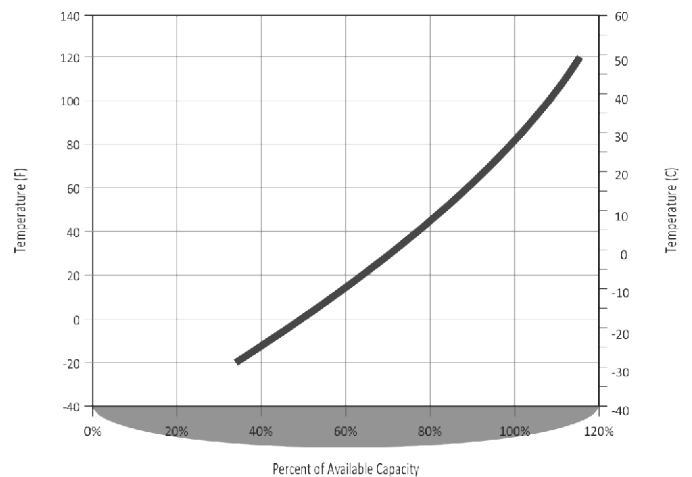

- A. The number of minutes a battery can deliver when discharged at a constant rate at 80°F (27°C) and maintain a voltage above 1.75 V/cell. Capacities are based on peak performance.
- B. The amount of amp-hours (Ah) a battery can deliver when discharged at a constant rate at 80°F (27°C) and maintain a voltage above 1.75 V/cell. Capacities are based on peak performance.
- C. Dimensions may vary depending on type of handle or terminal. Batteries should be mounted with 0.5 inches (12.7mm) spacing minimum.

- D. C.C.A. (Cold Cranking Amps) - the discharge load in amperes which a new, fully charged battery can maintain for 30 seconds at 0°F (-18°C) at a voltage above 1.2 V/cell.
- E. C.A. (Cranking Amps) - the discharge load in amperes which a new, fully charged battery can maintain for 30 seconds at 32°F (0°C) at a voltage above 1.2 V/cell. This is sometimes referred to as marine cranking amps @ 32°F or M.C.A. @ 32°F.
- F. Height taken from bottom of the battery to the highest point on the battery. Heights may vary depending on type of terminal.
- G. Terminal images are representative only.



800.423.6569 / +1.562.236.3000 / trojanbattery.com

27TMX DS2016_0907

© 2015 Trojan Battery Company, LLC. All rights reserved. Trojan Battery Company is not liable for damages that may result from any information provided in or omitted from this publication under any circumstances. Trojan Battery Company reserves the right to make adjustments to this publication at any time, without notice or obligation.

Loading and Transportation.

Preparation for transport.

Fundamentals

1. Preparation:

A: Uninstall the loading accessory. This allows for an economical and space-saving storage during transport.

B: Convert the lift from its operating position to its transport position.

2. Dismantling:

The loading accessory must be uninstalled before converting the lift to transport position.

Follow the steps for **Installation** in **reverse**

3. Varying Transport Positions:

There are two different transport positions for:
 ► **Models without Counterweights (Std)**
 ► **Models with Counterweights (K)**

The correct transport position does not depend on whether the model has an electric or manual winch.

Transport Position

GML/Std

AC-/DC-/M-Models without counterweights



GML/K

AC-/DC-/M-Models with counterweights

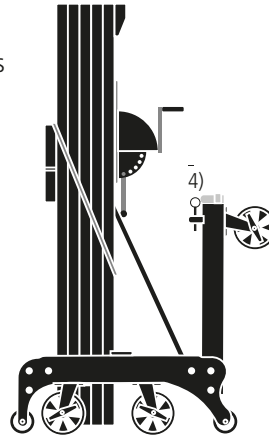

Exceptions:

There are some occasions where a GML may be loaded without having been previously converted to its transport position.

In these exceptional cases the lift may be loaded when:

1. The ramp being used when moving the lift onto the transport vehicle or trailer possesses a sufficient width and provides a sufficient load bearing capacity.

WARNING:

On a ramp with a steep slope, the lift may roll backwards. Therefore the lift must always be pushed onto the loading surface by at least two people (preferably more).

2. The lift is equipped with the optionally available forklift receptors and can be safely loaded onto the transport vehicle or trailer with a forklift.

WARNING:

When the lift is loaded using the forklift receptors, loading must **always occur from the rear to avoid damage to the mast system**



Always ensure that the forks on the loading forklift are inserted to an adequate depth in the forklift receptors on the GML lift.

Apart from the loading accessory, which must always be uninstalled, all other structural elements must remain on the lift on standard models (Std).

The loading accessory must always be transported, secured and stored separately.

On models with counterweights (K) the loading accessory **and** all other components, except for the structural elements, must be uninstalled before converting the lift to its transport position:

Components:

- 1) 1x Weight box
- 2) 12 x 35 lbs weights
- 3) 1x Steering arm
- 4) Safety bolt box (remain on the outrigger)

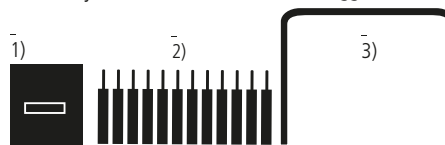

The loading accessory **and** components 1 - 3 must always be transported, secured and stored separately.

When necessary the counterweights may be stored in the weight box.

Take note: Gross weight ~ ca. 440 lbs

Loading and Transportation.

Basic Procedures.

Before loading, familiarise yourself with the requirements for the loading methods as well as for the vehicles/trailers for lift transportation. Read and obey the respective conditions.

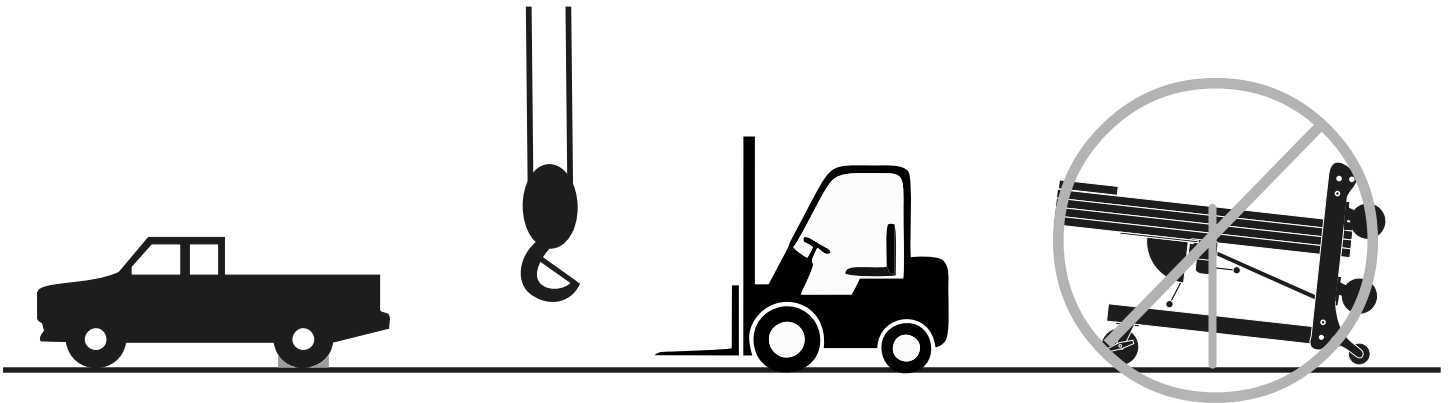

Transport vehicle/trailer:

1. The transport vehicle/trailer must be positioned on a firm, flat and level surface.
2. The transport vehicle/trailer must be appropriately secured to avoid rolling while the lift is loaded.
3. Ensure that the transport vehicle/trailer:
 - is big enough
 - has sufficient SWL/ towing capacity
 - has been provided with sufficient securing points.

Loading attachment:

1. When loading with a **crane/forklift** ensure that the lifting capacity of the crane/ forklift is sufficient in order to be able to load safely.
2. Ensure that the applied **belts/chains** for raising loads are without damage and have sufficient dimensions for the weight of the lift.
3. Take into account the weight specifications of the lift on the name plate of the chassis or/and the technical data within this operating manual.

Load safety:

1. The lift must be sufficiently secured by belts/chains when being transported.
2. Ensure that the applied belts/chains employed for safe loading are without damage and have sufficient dimensions.
3. Secure the lift properly and ensure that the belts/chains **DO NOT COME INTO CONTACT WITH THE MAST SYSTEM.**
4. Ensure that **the mast system is free of any obstructions and not put under strain by e.g. the belts/chains etc.**



Trailers with a ramp:

1. Follow steps 1-3 of the section 'Transport vehicle/Trailer'.
2. When using a ramp ensure that it
 - has sufficient load bearing capacity
 - is stable enough
 - cannot be bent/ruptured
 - is secured to avoid slipping

Loading and Transportation.

Loading while tilting.
Loading by crane.

Before loading, familiarise yourself with the requirements for the loading methods as well as for the vehicles/trailers for lift transportation. Read and obey the respective conditions.

1. Tilting

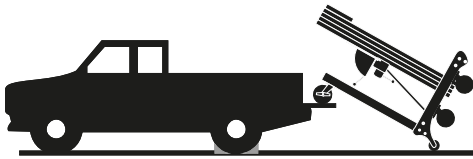

1. Place the lift in a tilted position ready to be loaded upon the vehicle for transportation.
2. Confirm that the mast system is in a lowered position and properly secured by the mast element transport safety hook. Examine the lift for any loose parts and make sure that the lateral outriggers (if equipped with) are secured and in a folded position.
3. Utilise the correct lifting methods to either load the lift onto the loading area or instead load it directly into the transport vehicle or trailer itself.
4. Engage the safety brakes on the casters that are in contact with the surface of the loading area.
5. Ensure that the lift is secured properly with the appropriate belts/chains in order to avoid any uncontrolled movements or any possibility of it tipping-over etc. Avoid damage to any lift components when securing it.

Unloading:

6. To unload the lift from its transport position loosen the belts/chains and disengage the safety brakes on the casters.
7. Push the lift carefully and slowly towards the edge of the vehicle's loading area.
8. Utilise the correct lifting methods to unload the lift from the transport vehicle or trailer directly onto the ground.

WARNING: When the lift is being set onto the ground ensure that you keep a safe distance from it! To not do so will increase the likelihood injuries being uncurrred.

2. Crane

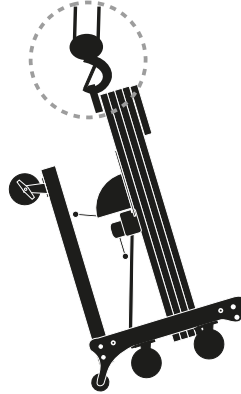

1. Place the lift in position for transportation under the hook of the crane.
2. Confirm that the mast system is in a lowered position and properly secured by the mast element transport safety hook. Examine the lift for any loose parts.
3. Ensure that the crane has sufficient lifting capacity.
4. Utilise the lifting hook of the crane for the prescribed hoisting ring of the lift only. The ring is located on the upper end of the mast system.
5. Clip the lifting hook of the crane onto the hoisting ring of the lift. Make sure that it is securely fastened before the lift is elevated.
6. Use the crane to carefully elevate the lift and position it onto the loading area as required.
7. Lower the lift carefully onto the ground and disconnect the crane from the lift.
8. Engage the safety brakes on the casters that are in contact with the surface of the loading area.
9. Ensure that the lift is secured properly with the appropriate belts/chains in order to avoid any uncontrolled movements or any possibility of it tipping-over etc. Avoid damage to any lift components when securing it.

Unloading:

1. To unload the lift from its transport position on the vehicle/trailer, loosen the belts/chains and then disengage the safety brakes on the casters.
2. Push the lift carefully and slowly to a position in which unhindered and safe access by crane is possible.
3. Clip the lifting hook of the crane onto the hoisting ring of the lift. Make sure that it is securely fastened before the lift is elevated.
4. Use the crane to carefully elevate the lift from the loading area of the vehicle/trailer and set it slowly down to the ground.
5. Disconnect the crane from the lift.



WARNING:
 > **When the lift is being set onto the ground ensure that you keep a safe distance from it!**
 > **Ensure that no one remains beneath the lift while it is being loaded or unloaded!**

Loading and Transportation.

Loading by forklift.

Only for models with (optionally available) forklift receptors.

Before loading, familiarise yourself with the requirements for the loading methods as well as for the vehicles/trailers for lift transportation. Read and obey the respective conditions.

3. Forklift

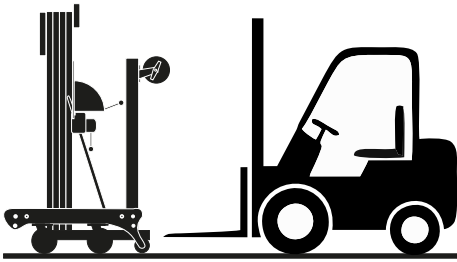

1. Place the lift in transport position in front of the forklift.
2. Confirm that the mast system is in a lowered position and properly secured by the mast element transport safety hook. Examine the lift for any loose parts and make sure that the lateral outriggers (if equipped with) are secured and in a folded position.
3. Ensure that the forklift has sufficient lifting capacity.
4. Adjust the forklift receptors by pulling out their locking pins.
5. Position the forklift carefully and slowly behind the lift and adjust the prongs of the forks to the forklift receptors. The adjustment and the elevation of the lift must always occur **from the rear** of the lift! Otherwise the mast element might be damaged.
6. After ensuring that the prongs of the forks and the receptors have been adjusted correctly, raise the lift carefully. Guarantee that the forks have been sufficiently inserted into the forklift receptors in order to avoid any danger of tipping-over while the lift is being raised.
7. Raise the lift carefully by using the forklift and position it above the desired loading area.
8. Lower the lift carefully onto the ground and remove the forks slowly.



Unloading:

9. Position the lift manually at the place required on the loading area.
 10. Engage the safety brakes on the casters that are in contact with the surface of the loading area.
 11. Ensure that the lift is secured properly with the appropriate belts/chains in order to avoid any uncontrolled movements or any possibility of it tipping-over etc. Avoid damage to any lift components when securing it.
1. To unload the lift from its transport position, loosen the belts/chains and then disengage the safety brakes on the casters.
 2. Ensure that the forklift has sufficient lifting capacity.
 3. Push the lift carefully and slowly to a position in which unhindered and safe access by forklift is possible.
 4. Ensure that the lift is positioned to allow safe and easy access to the **rear side** of the lift by the forklift! Otherwise the mast element might be damaged.
 5. If necessary adjust the forklift receptors by pulling out their locking pins.
 6. Position the forklift carefully and slowly behind the lift and adjust the prongs of the forks to the forklift receptors.
 7. To raise the lift carefully guarantee that the forks have been sufficiently inserted into the forklift receptors in order to avoid any danger of tipping-over while the lift is being raised.
 8. Elevate the lift carefully from the loading area by using the forklift and then set it down slowly onto the ground.



WARNING:
Keep safe distance! The lift may tip from the forklift.

Loading and Transportation.

Movement onto the trailer.

Before loading, familiarise yourself with the requirements for the loading methods as well as for the vehicles/trailers for lift transportation. Read and obey the respective conditions.

4. Movement

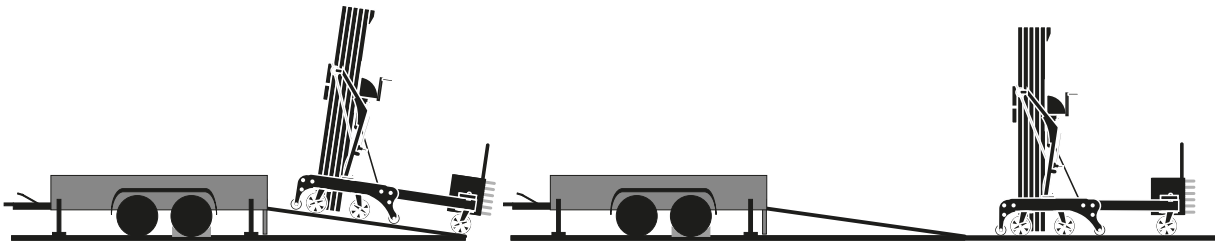

1. Place the lift in its transport position in front of the trailer. The trailer must be braced and its brake must be engaged securely. The wheels of the trailer must also be secured with wedges to prevent rolling.
2. Only move the lift onto the trailer if you can ensure that the ramp possesses sufficient load bearing capacity and stability as well as being adequately secured against slipping.
3. Confirm that the mast system is in a lowered position and properly secured by the mast element transport safety hook. Examine the lift for any loose parts and make sure that the lateral outriggers (if equipped with) are secured and in a folded position.
3. Move the lift with at least two or more people to be able to propel it up the ramp and onto the trailer.

! WARNING:
The lift may roll backwards. If the lift is not secured against rolling, injuries may occur!

4. Position the lift manually at the place required on the loading area.
5. Engage the safety brakes on the casters that are in contact with the surface of the loading area.
6. Ensure that the lift is secured properly with the appropriate belts/chains in order to avoid any uncontrolled movements or any possibility of it tipping-over etc. Avoid damage to any lift components when securing it.

Unloading:

1. Ensure that you have enough space between the trailer and any possible obstructions nearby. The lift may roll uncontrollably backwards.
2. To unload the lift loosen the belts/chains and then disengage the safety brakes on the casters.
3. Move the lift carefully and slowly towards the place where the edge of the trailer meets the ramp. The ramp must possess sufficient load bearing capacity and stability as well as being adequately secured against slipping.
4. Secure the lift as far as possible to avoid it rolling down the ramp and thereby decreasing the risk of any accidents or injury.
5. If the lift is to be unloaded off the loading area by means of a ramp, make sure that at least two burly people are available to enable the lift to roll down in a controlled manner.
6. Let the lift move slowly down the ramp. At the moment it has left the ramp completely and is in contact with the level ground, it can then be released.

! WARNING:
Ensure that you have enough space available near the trailer to enable you to evade the lift if it rolls uncontrollably backwards.

Technical Data

GML800+ M-Series	GML800+/10/M	GML800+/15/M	GML800+/20/M	GML800+/25/M
Working height - Standard Fork up:	129 in	185 in	240 in	295 in
Transport position - Height/Length/Width:	77/43/31 in	77/43/31 in	77/43/31 in	77/43/31 in
Working position - Height/Length/Width	77/76/31 in*	77/76/31 in*	77/76/31 in*	77/78/31 in*
Safe working load (load center: 28 cm):**	1984 lbs	1873 lbs	1763 lbs	1763 lbs
Weight Chassis + outrigger:	679 lbs	758 lbs	842 lbs	978 lbs
K-Models additional:	14 lbs	14 lbs	14 lbs	14 lbs
Counterweights with Box:	467 lbs	467 lbs	467 lbs	467 lbs

*Outrigger backwards. Outrigger forwards = 110 in. ** Without Loading device.

GML800+ AC-Series	GML800+/10/AC	GML800+/15/AC	GML800+/20/AC	GML800+/25/AC
Working height - Standard Fork up:	129 in	185 in	240 in	295 in
Transport position - Height/Length/Width:	77/43/31 in	77/43/31 in	77/43/31 in	77/43/31 in
Working position - Height/Length/Width	77/76/31 in*	77/76/31 in*	77/76/31 in*	77/76/31 in*
Safe working load (load center: 28 cm):**	1984 lbs	1873 lbs	1763 lbs	1763 lbs
Weight Chassis + outrigger:	718 lbs	798 lbs	941 lbs	1018 lbs
AC-Drive:	230/110V	230/110V	230/110V	230/110V
K-Models additional:				
Counterweights with Box:	467 lbs	467 lbs	467 lbs	467 lbs

*Outrigger backwards. Outrigger forwards = 110 in. ** Without Loading device.

GML800+ DC-Series	GML800+/10/DC	GML800+/15/DC	GML800+/20/DC	GML800+/25/DC
Working height - Standard Fork up:	129 in	185 in	240 in	295 in
Transport position - Height/Length/Width:	77/43/31 in	77/43/31 in	77/43/31 in	77/43/31 in
Working position - Height/Length/Width	77/76/31 in*	77/76/31 in*	77/76/31 in*	77/76/31 in*
Safe working load (load center: 28 cm):**	1984 lbs	1873 lbs	1763 lbs	1763 lbs
Weight Chassis + outrigger:	681 lbs	760 lbs	901 lbs	981 lbs
AC-Drive:	2x 12V/105Ah	2x 12V/105Ah	2x 12V/105Ah	2x 12V/105Ah
K-Models additional:				
Counterweights, Box, Battery Carrier	487 lbs	487 lbs	487 lbs	487 lbs

*Outrigger backwards. Outrigger forwards = 110 in. ** Without Loading device.

GML800+ Wheel load	GML800+ /Std	GML800+ /K
Safe working load up to 881 lbs	440 lbs/caster	1102 lbs/at the front
Safe working load up to 1322 lbs	551 lbs/caster	1653 lbs/at the front
Safe working load up to 1984 lbs	661 lbs/caster	2204 lbs/at the front

Declaration of Conformity

CE-Declaration of Conformity
 according to guideline 2006/42/EG, appendix II 1.A
 - Original EC-Declaration of Conformity -



Norbert Wienold GmbH

Industriegebiet Waldstr. 35 | 48488 Emsbüren



We hereby declare that the design, the construction and the implementation of the Glass and Material Lift listed as follows are in accordance with the essential Health & Safety Requirements of the EC- Machinery Guideline, that are applicable to these machines.

OELGEMÖLLER Planning+Engeneering
 Hessbergstraße 12
 48488 Emsbüren

1. EC-Guideline
 Machinery Guideline 2006/42/EG
 Low Tension Guideline 2006/95/EG
 Noise Emission Guideline 2003/10/EG
2. Applied, harmonising EN-Norms
 Cranes - General Construction - Part 1: General principles and requirements DIN EN 13001
 Crane Safety - General Construction - Part 2: Load impacts DIN EN 13002
 Cranes - Power propelled winches and hoists - Part 1: Power propelled winches DIN EN 14492-1
 Cranes - Power propelled winches and hoists - Part 2: Power propelled hoists DIN EN 14492-2
 CE-Prescriptions DIN EN 12100 Safety of machines - General design principles
3. Installation and declarations of conformity of our suppliers: engines, electrical accessories etc.
4. The special technical documents according to appendix V part B and the assembly instruction according to appendix VI of guideline 2006/42/EG have been issued. The implementation of the requirements according to the low tension guideline, as per appendix 1, no. 1.5.1 of guideline 2006/42/EG have been ensured.

Raising, Lowering, Holding and Moving of loads

Product: Wienold Glass and Material Lift

Manufacturer:

Model: GML 800

Norbert Wienold GmbH

Serial no.: GML 800-XXXXX

Industriegebiet Waldstr. 35

Year of construction: 2015

D-48488 Emsbüren, Germany

Power of attorney of Norbert Wienold GmbH

Place of issue: Emsbüren

Position of the signatory

in the company: Managing director

Emsbüren, 15 December 2015

Place, Date, Signature

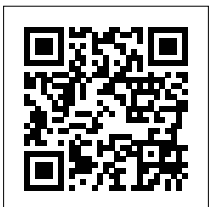

Norbert Wienold GmbH
Industriegebiet Waldstr. 35a
48488 Emsbüren
Germany

Tel. +49 59 03 - 93 94 0
Fax +49 59 03 - 93 94 50

www.wienold-lifte.de
e-mail: info@wienold-lifte.de

Rental stations and service facilities:

Emsbüren
Walsrode
Brandenburg
Leverkusen
München